

# EDS-xxx

## 500W DC OUTPUT UPS

### GENERAL FEATURES:

- Battery cut off when battery low
- 3 state battery charging
- Configurable maximum current charging level
- Step mains to battery without voltage dips
- Battery not included
- Battery temperature sensor (optional)
- Battery low alarm
- Battery test
- Mains failure alarm
- UPS failure alarm
- Advanced configuration via RS232
- Ethernet or CAN Bus connection (optional)
- Redundance ORing diode (optional)
- Railway applications version (optional)



MODELS	Input voltage range	Nominal output voltage	Maximum output power	Maximum output current	Maximum Output peak current from battery
<b>EDS-500-5243</b>	110 ... 230Vac	12V	500W	36.7A	50A 30s
<b>EDS-500-5247</b>		24V		18.4A	30A 30s
<b>EDS-500-5249</b>		48V		9.19A	15A 30s
<b>EDS-500-5251</b>		110V		4.02A	5A 30s

References subject to special MOQs and lead times. Please consult Premium's Sales Dept. and web site

Specifications are subject to change without notice. These products are not intended for use as critical components in life support or nuclear systems.

<b>INPUT</b>	
Input voltage range	110 ... 230Vac
Mains frequency range	47 ... 63Hz
Inrush current	<30A
Power factor	0.98 at full load
Efficiency	See table
<b>OUTPUT</b>	
Output voltage range	-0, +20%Von
Line regulation	<0,2%
Maximum ripple	See table
Maximum load capacitance	See table
<b>BATTERY</b>	
Battery charging method	Bulk / absorption / float
Maximum charging current	Configurable range depends on model (see table on page 1)
Maximum charging current tolerance	10%
Battery temperature compensation	2.5mV/K/cell
Battery test	By capacity measurement discharging over the load
<b>ENVIRONMENTAL</b>	
Storage temperature	-25 ... 80°C
Operating temperature	-25 ... 55°C (Po = nom) -25 ... 70°C (Po = 62.5% nom)
Maximum Relative humidity	95% with no condensation
Cooling	Natural convection
MTBF	350.000h @ 40°C according to IEC61709
<b>EMC</b>	
Emission	EN61000-6-4 (EN50121-3-2 and EN50121-4 for option T)
Immunity	EN61000-6-2 (EN50121-3-2 and EN50121-4 for option T)
<b>SAFETY</b>	
Safety	IEC62368-1
Dielectric strength Input / Output, Signals	3000Vac 50Hz 1 min
Dielectric strength Earth / Input	1500Vac 50Hz 1 min
Dielectric strength Output / Earth, Signals	500Vac 50Hz 1 min
Fire and smoke	EN45545-2 HL1 HL2 and HL3 (only for option T)
<b>MECHANICAL</b>	
Size	186.5 x 87 x 124.4 mm
Weight	1490 gr.
<b>CONTROL</b>	
Battery reconnection button	For starting up without mains presence
LEDs	<p>Power on (Green)</p> <p>Charging (Ambar):</p> <ul style="list-style-type: none"> <li>• Blink: Quick Charge</li> <li>• Fixed: Floating/Battery charged</li> </ul> <p>Battery Failure (Red):</p> <ul style="list-style-type: none"> <li>• Led on: Battery test failed</li> <li>• Slow blink: Battery not present</li> <li>• Fast blink: Battery temperature sensor not present</li> </ul> <p>AC or charger failure (Red):</p> <ul style="list-style-type: none"> <li>• Led on: Vout out of range</li> <li>• Slow blink: AC input out of range</li> </ul>
Mains failure alarm	Mains out of range. Closed contact when alarm
Battery low alarm	Battery discharged. Closed contact when alarm
Urgent failure alarm	Maintenance required. Closed contact when alarm. Alarm cases: <ul style="list-style-type: none"> <li>• Battery not present</li> <li>• Battery test failed</li> <li>• Charger malfunction</li> <li>• Charger temperature out of range</li> </ul>
UPS failure alarm	Vout out of range. Closed contact when alarm.
Alarms spec:	
Type	Solid state relay
Maximum switching voltage	60 V
Maximum switching current	0.2A

PROTECTIONS	
Against overloads and short-circuits	Current limiting
Battery protection against deep discharges	Battery cut off
Battery protection against overloads	Current limiting and fuse
Against Input over-currents	Fuse

## ORDERING CODES

Part Number	Output / Battery						Maximum Output current			Effic [%]	Maximum charging current selection		
	Nom [V]	Float [V] *	Const Volt [V] *	Cut off [V] *	Max Ripple [mV]	Max Cap [mF]	Cont. [A]	1 min [A]	From Battery [A]		Min [A]	Nom [A] *	Max [A]
<b>EDS-500-5243</b>	12	13.6	14.5	10.5	100	15	36.7	36.7	50 (30s)	90	2.5	16	20
<b>EDS-500-5247</b>	24V	27.1	29.0	21	100	15	18.4	20	30 (30s) 32 (1s)	92	1.25	8.0	10
<b>EDS-500-5249</b>	48V	54.2	58.0	42	150	15	9.19	10	15 (30s) 16 (1s)	93	0.63	4.0	5.0
<b>EDS-500-5251</b>	110V	124.2	132.9	96.2	300	2.7	4.02	4.5	5 (30s) 7 (1s)	93	0.3	1.75	2.2

\* Default factory settings

References subject to special MOQs and lead times. Please consult Premium's Sales Dept. and web site

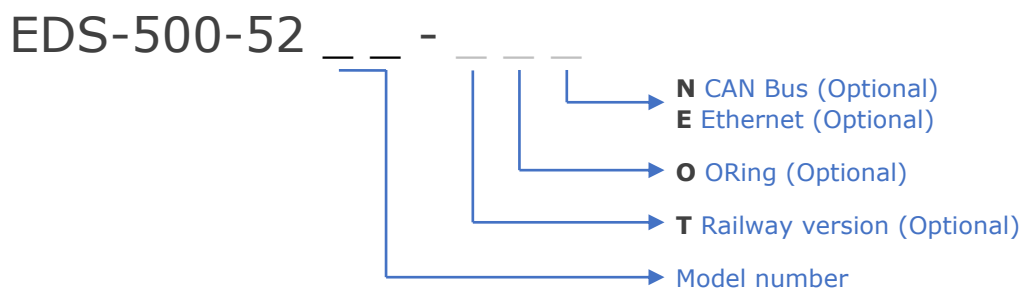

Accessories must be ordered in a separated order line

## BLOCKS DIAGRAM

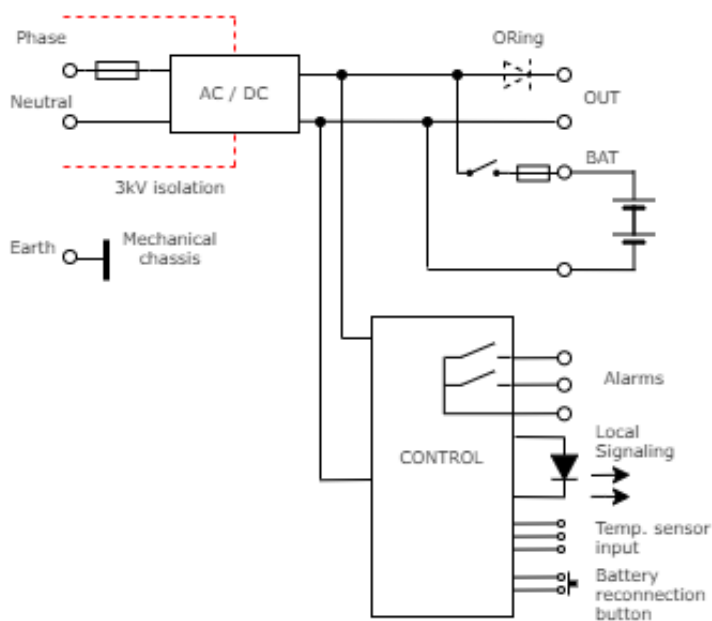

## CONNECTIONS

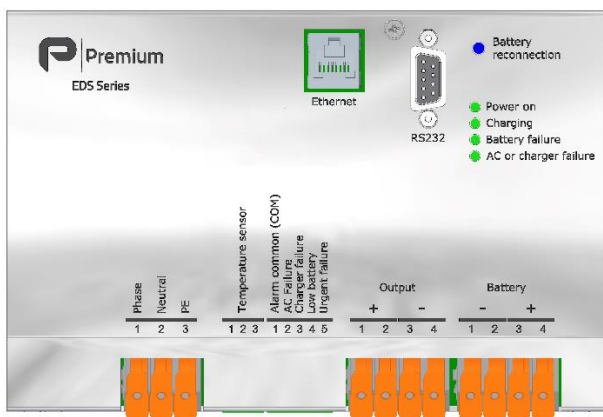
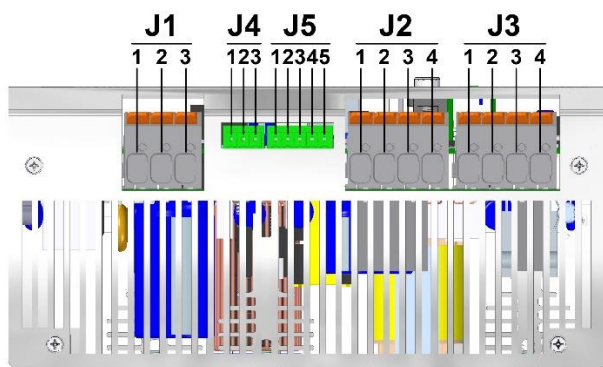

J1-1	Mains Line	Cable cross section 0,75 ... 6 mm <sup>2</sup>
J1-2	Mains Neutral	
J1-3	Protective EARTH	
J2-1, 2	+ Vout	
J2-3, 4	- Vout	
J3-1, 2	-VBat	
J3-3, 4	+ VBat	
J4-1	Temp sensor +5V	Temperature sensor not included
J4-2	Temp sensor	
J4-3	Temp sensor GND	
J5-1	Com alarms	Mating connector: Phoenix Contact MC 1,5/ 5-ST-3,81 (not included)
J5-2	Mains alarm	
J5-3	UPS alarm	
J5-4	Low Bat.alarm	
J5-5	Urgent failure	

## POWER DERATING vs TEMPERATURE



## DESCRIPTION

This series consists of three models of a power supply-charger which, in the presence of mains voltage, supplies regulated voltage, while at the same time charging the battery in a controlled way. The range is ideal for charging lead-acid batteries of 12V, 24V, and 48V with capacities of up to 96Ah, 48Ah, and 24Ah respectively.

The device comprises a switched-mode power supply and a three steps battery charger circuitry. It also incorporates an alarm circuitry which acts independently, when a mains, UPS or battery condition occurs. The alarm outputs are the switched, potential-free contacts of relays.

### Mains operation

When the mains supply is on, the output current is obtained directly from the power supply. The maximum battery charging current can be selected by the user through RS-232 connection. The maximum battery charging current will be equal to the set current or equal to the rated current less the output current; the floating voltage will be equal to the output voltage.

The system allows the temporary supply of an output current higher than the rated current. The average of this additional current, which is obtained from the battery, should not exceed the charging current as, otherwise, the battery would finally discharge.

If the power supply has no output, due to a mains voltage outage or to a failure in the power supply, the supply failure alarm will be triggered.

### Operation without mains supply

When there is no mains supply, the battery comes, uninterruptedly, into operation and the output current is obtained from the battery. The output voltage will then depend on the battery discharge curve.

If the battery runs flat, the low battery alarm will be triggered. It will be disconnected from the output by way of a relay to prevent a deep discharge of the battery. When the mains supply returns, the UPS may take several minutes to supply the established battery charging current. During this time, the battery is charged with a small current until the low battery status is overcome. At that moment, the low battery alarm is reset, the relay closes, and the battery starts to charge normally.

### Battery temperature sensor

An optional temperature sensor attached to the battery can be connected to the equipment. If it is used, charging and floating battery voltages are compensated according to battery temperature.

## INSTALLATION

Make the connections according to the table figure

If the battery charging current required is different from the factory set, this can be changed through RS-232 connection

### For safety reasons it is required:

To incorporate an easily accessible means of disconnecting from the mains supply.

Upon replacing the mains fuse, make sure one of the same rating is used and with the power supply disconnected from the mains.

To provide the equipment with a protective enclosure, in compliance with the Electrical Safety Regulations and Directives in the country where it is installed.

To use a mains connection cable with a cross section of at least 0.75mm<sup>2</sup>.

## ORing FEATURE

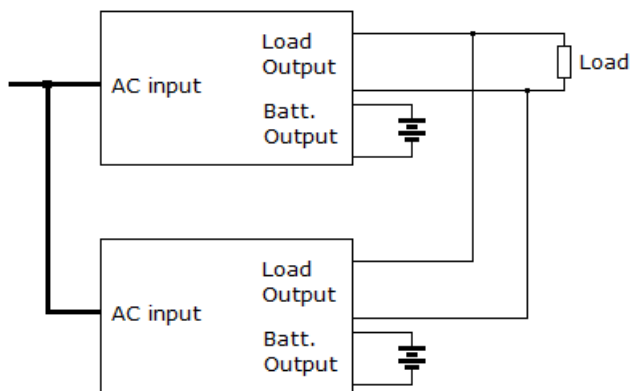

The optional ORing feature enables the parallel connection of several power supply-chargers. In this manner, the load current is shared among the units and redundancy is introduced in the power system for high reliability.

The implemented ORing is an active one, based on FET transistor, and thus minimizing power loss in this circuit.

## CHARGING CHARACTERISTIC

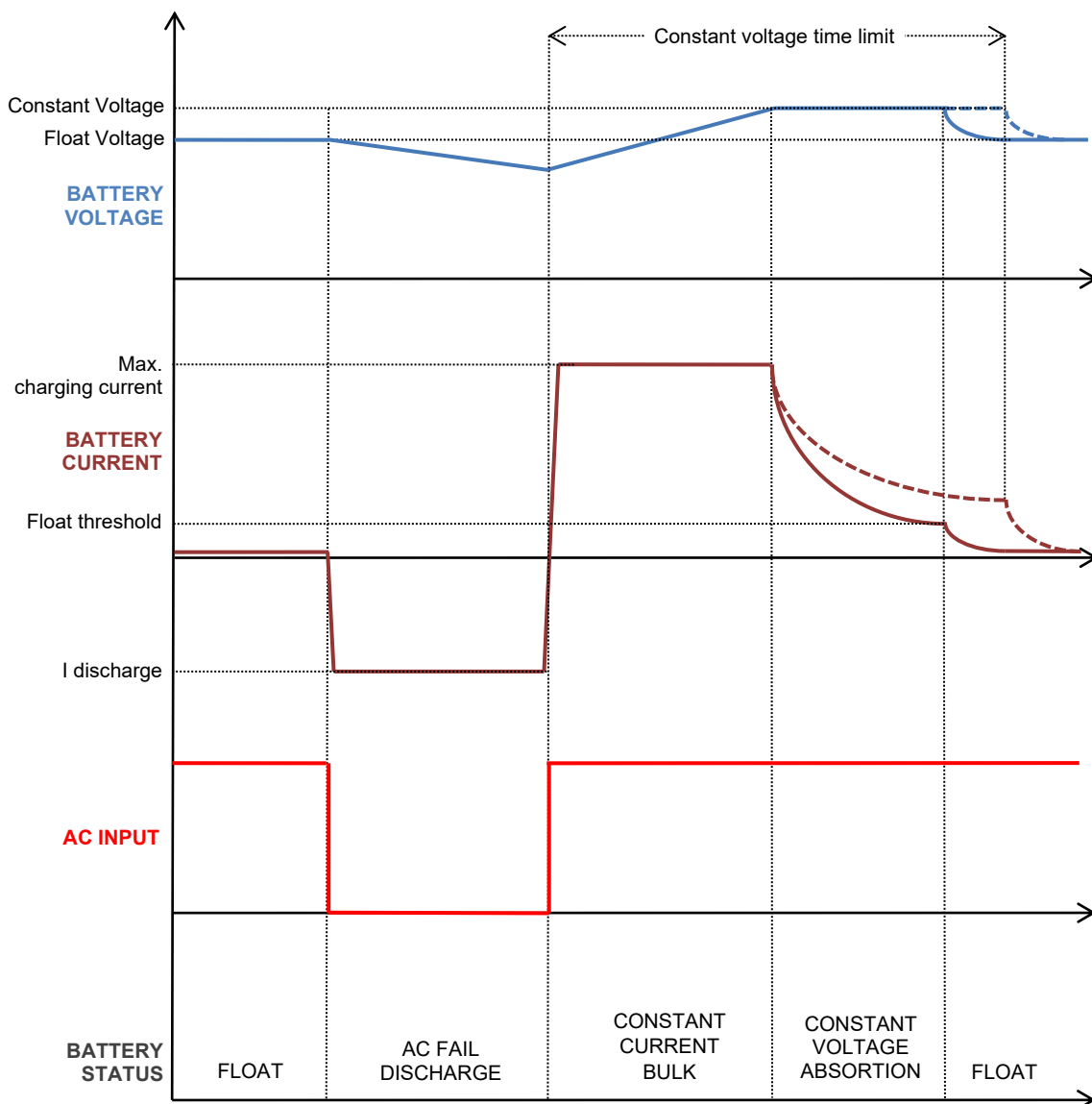

## CANopen Communication Protocol

The optional CAN Module enables CANopen application protocol.

### CAN Data Frame

Can protocol uses frames to send and receive data between the device and other nodes on the CAN Bus. The structure of the CAN frame is the following one:

SoF	COB-ID	RTR	Control Field	Data	CRC	ACK	EoF
1 bit	11 bits	1 bit	6 bits	0-8 bytes	16 bits	2 bits	7 bits

### LSS Service

Layer Setting Service. It offers the possibility to inquire and change the settings of certain parameters of the local layers on a CANopen module via CAN Network. The parameters that can be read and/or written by using LSS service are:

- Node-ID of the CANopen Slave.
- Bit timing parameters of the physical layer (baud rate).
- LSS address.

By default, CANopen devices start without CANopen Node-ID (0xFF) and baudrate of 250 kbit. Node ID must be set in order to communicate with the device.

### NMT Service

The Network Management is used to control the Nodes inside the network and its behaviour. This service uses a master/slave relationship where the master controls the states of the slaves.

### SDO Service

Service Data Object is used to have access to all the data defined in the Object Dictionary. SDO service allows the transmission and reception of objects of any size using a client/server communication. If SDO is not able to send all the data in one frame, it will segment it and send the data using multiframe format.

### Object Dictionary

The Object dictionary shows all the accesible data and the application and communication parameters inside the device. The dictionary sorts the data using and indexes and subindexes, which will be used by the CANopen protocol to map all the data.

#### Use cases:

#### LSS Service: Change Node ID

Tx/Rx	CAN Id	DLC	Message	Notes
Tx	7E5	8	04 01 00 00 00 00 00 00	Set nodes to configuration mode
Tx	7E5	8	11 XX 00 00 00 00 00 00	Set node ID to XX
Rx	7E4	8	11 __ 00 00 00 00 00 00	If __==00, node changed correctly
Tx	7E5	8	04 01 00 00 00 00 00 00	Set nodes to operation mode

#### SDO Service: (Node ID = 0x01)

Tx/Rx	CAN Id	DLC	Message	Notes
Tx	601	8	40 04 60 01 00 00 00 00	Read Index 6004, subindex 01
Rx	581	8	43 04 60 01 0F D4 00 00	Return value 00 00 D4 0F = 54287 mV
Tx	601	8	2F 03 60 00 04 00 00 00	Write index 6003 subindex 00 to 4
Rx	581	8	60 03 60 00 00 00 00 00	Write OK

### Object Dictionary:

Idx	Sub	Type	RW	Notes
6001	00	INT32	ro	Output Power
6002	00	INT32	ro	Main Forward Power
6003	00	UINT8	rw	Output Type
6004	01	UINT32	rw	Maximum Output voltage in mV
6004	02	UINT32	rw	Minimum Output voltage in mV
6004	03	UINT32	rw	Nominal output voltage in mV
6005	01	INT32	rw	Maximum battery temperature in m°C
6005	02	INT32	rw	Minimum battery temperature in m°C.
6006	00	UINT16	rw	Battery current for transition to floating from quick charge in mA
6007	00	UINT32	rw	Output voltage in floating state in mV
6008	00	UINT32	rw	Output voltage in quick charge state in mV
6009	01	UINT32	rw	Disconnection voltage lower bound in mV
6009	02	UINT32	rw	Disconnection voltage upper bound in mV
600A	00	UINT16	rw	Maximum time of quick charge state in hours
600B	00	INT16	rw	Maximum charging current in mA
600C	00	UINT16	rw	Maximum number of power up retries
600D	00	UINT16	rw	Time between power up retries in minutes
600E	00	UINT16	rw	Time in minutes for disconnection of the battery when AC is not available
600F	00	UINT16	rw	Number of times a battery can be above maximum output voltage
6010	00	UINT16	rw	Time in seconds to disconnect the battery when above the maximum output voltage
6011	00	UINT16	rw	Time in seconds to clear a battery overvoltage alarm
6012	00	UINT16	rw	Timeout in minutes to clear the number of times a battery is over maximum voltage
6013	00	UINT16	rw	Time in seconds for the end of autonomy alarm to trigger
6014	00	UINT8	rw	Battery presence
6015	00	UINT32	rw	Limit voltage to consider a battery test failed in mV
6016	00	UINT32	rw	Capacity discharged in a battery test to finish it in mAh
6017	00	UINT16	rw	Period of the battery test in weeks
6018	00	UINT16	rw	Maximum time of an attempt of battery test
6019	00	UINT16	rw	Time in seconds in a battery test that voltage must be below v_fin to consider the attempt failed
601A	00	UINT16	rw	Number of retries of battery test
601B	00	UINT16	rw	Retry time of a failed battery test in minutes
601C	00	UINT16	rw	Maximum time in minutes in recovering battery state
601D	00	UINT16	rw	Minimum time to consider battery charged from floating state in hours
601E	00	INT16	rw	Minimum temperature to apply temperature compensation in d°C
601F	00	INT16	rw	Maximum temperature to apply temperature compensation in d°C
6020	00	UINT8	rw	Enable compensation
6021	00	UINT16	rw	Temperature compensation in quick charge state in mV/°C
6022	00	UINT16	rw	Temperature compensation in floating state in mV/°C
6023	00	UINT16	rw	Time in ms that conditions have to be met constantly to change from quick charge to floating state
6024	00	UINT16	rw	Number of overloads allowed
6025	00	UINT16	rw	Time between test to overcome overload state in seconds
6026	00	UINT32	rw	Immediate disconnection voltage in mV
6027	00	INT32	ro	Current out of the AC/DC converter in mA
6028	00	INT32	ro	Current sensed charging the battery in mA
6029	00	INT32	ro	Output voltage in mV
602A	00	INT32	ro	Internal temperature in m°C
602B	00	UINT32	ro	Temperature sensed in the battery current probe in m°C. If not present, it will return max value.
602C	00	INT32	ro	Battery voltage in mV
602D	00	INT32	ro	Overall battery current in mA. Positive values correspond to charging and negatives to discharging
602E	00	INT32	ro	Current sensed discharging the battery in mA
602F	00	UINT8	ro	Current internal battery charger state

## RS-232

The equipment can be locally configured through RS-232 connection. The configuration for the RS232 communication channel is the following:

- **Baud rate:** 115200
- **Parity:** None
- **Bits:** 8
- **Stop bits:** 1
- **Flow control:** none

### Available commands:

#### Generic commands:

Command	Type	Description
id	String	Get the ID of the product family
version	String	Get the version of the firmware

#### Measurement commands:

Command	Type	Description
i_converter	Float	Current out of the AC/DC converter in mA
i_bat_charge	Float	Current sensed charging the battery in mA
v_out	Float	Output voltage in mV
temp_int	Float	Internal temperature in m°C
temp_bat	Float or String	Temperature sensed in the battery current probe in m°C. If not present, it will return "NOT CONNECTED"
v_bat	Float	Battery voltage in mV
i_bat_discharge	Float	Current sensed discharging the battery in mA.
i_bat	Float	Overall battery current in mA. Positive values correspond to charging and negatives to discharging.

#### Configurable parameters:

The device has configurable parameters whose value can be read or written. To read a value, prepend "get " at the beginning; to write a value, prepend "set " at the beginning and append the desired value at the end.

Command	Description
v_flot	Output voltage in floating state in mV.
v_carga	Output voltage in quick charge state in mV.
v_fin	Limit voltage to consider a battery test failed in mV.
cap_desc	Capacity discharged in a battery test to finish it in mAh.
desc_v_max	Disconnection voltage upper bound in mV.
desc_v_min	Disconnection voltage lower bound in mV.
desc_inm	Immediate disconnection voltage in mV.
vout_nom	Nominal output voltage in mV.
vout_max	Maximum output voltage in mV.
vout_min	Minimum output voltage in mV.

#### Configurable parameters (continues):

Command	Description
ilim	Maximum charging current in mA.
comp_flot	Temperature compensation in floating state in mV/°C
comp_carga	Temperature compensation in quick charge state in mV/°C
i_flot	Battery current for transition to floating from quick charge in mA.
comp_t_max	Maximum temperature to apply temperature compensation in d°C
comp_t_min	Minimum temperature to apply temperature compensation in d°C
t_min_flot	Minimum time to consider battery charged from floating state in hours.
t_lim_carga	Maximum time of quick charge state in hours.
periodo	Period of the battery test in weeks.
tlim_prueba	Maximum time of an attempt of battery test.
rein	Number of retries of battery test.
t_rein	Retry time of a failed battery test in minutes.
tbat_alta	Maximum battery temperature in m°C.
tbat_baja	Minimum battery temperature in m°C.
hab_comp	Enable compensation.
bat_presence	Battery presence.
time_between_overload_retries	Time between test to overcome overload state in seconds.
RCVcte_TempPasoFlot	Time in ms that conditions have to be met constantly to change from quick charge to floating state.
PrbBat_TTensLim	Time in seconds in a battery test that voltage must be below v_fin to consider the attempt failed.
TFinAutDesc	Time in minutes for disconnection of the battery when AC is not available.
TempAlarmFinAut	Time in seconds for the end of autonomy alarm to trigger.
PowerUP_TempReint	Time between power up retries in minutes.
PowerUP_NumReint	Maximum number of power up retries.
TAlarmOnBatTensMax	Time in seconds to disconnect the battery when above the maximum output voltage.
TAlarmOffBatTensMax	Time in seconds to clear a battery overvoltage alarm.
NumReint_BatTensMax	Number of times a battery can be above maximum output voltage.
TempEspFin_BatTensMax	Timeout in minutes to clear the number of times a battery is over maximum voltage.
number_of_overload_retries	Number of overloads allowed.
maximum_recovering_battery_time	Maximum time in minutes in recovering battery state.

## DIMENSIONS

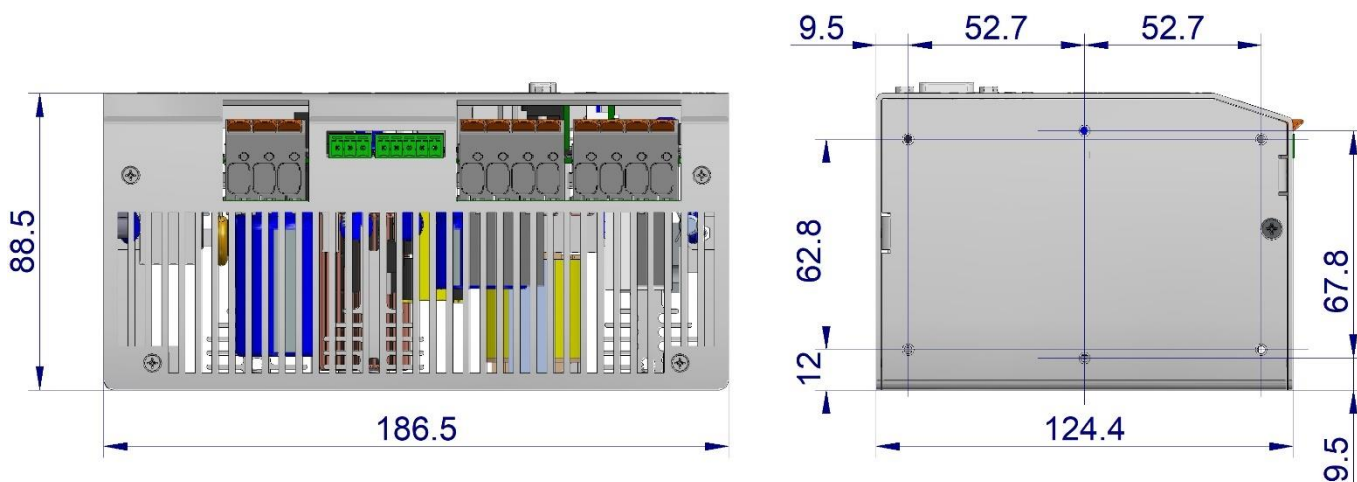

## ACCESSORIES

Description	CODE
DIN rail clip set	NP-9441
Mounting brackets set	NP-9442
Temperature sensor (cable 2m)	NP-9433

**NP-9441**

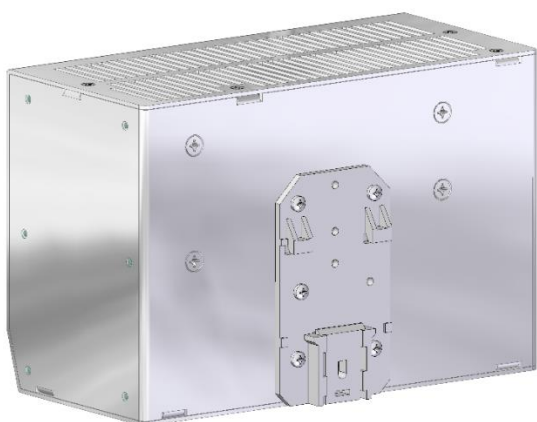

**NP-9442**

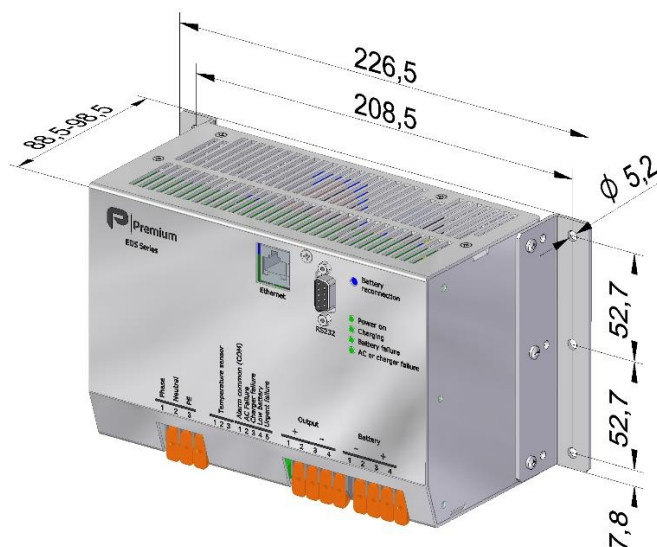

**NP-9433**

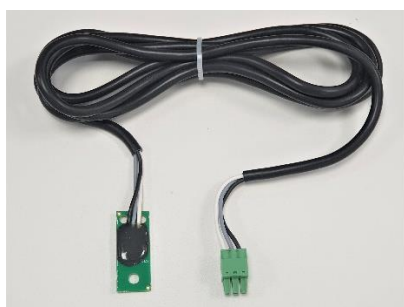

The sensor may increase the battery life, specially when it suffers relevant perodes of time with ambient temperatures  $>35^{\circ}\text{C}$  or  $<15^{\circ}\text{C}$

The sensor must be installed in the battery housing  
It has a mounting hole of diameter 5mm



## EU, UKCA DECLARATION OF CONFORMITY

The undersigned, representing the following:

Manufacturer: PREMIUM, S. A.,  
Address: C/ Dolors Aleu 19-21, 08908 L'Hospitalet de Llobregat, SPAIN

herewith declares that the product:

Type: DC UPS  
Models: **EDS-xxxx-5243... 5249**

is in conformity with the provisions of the following EU directive(s):

2014/35/EU SI 2016 No 1101	Low voltage / The electrical equipment (safety) regulations
2014/30/EU SI 2016 No 1091	EMC / Electromagnetic compatibility regulations
2011/65/EU Annex II and its amendment 2015/863/EU SI 2012 No. 3032	RoHS / Restriction of the use of certain hazardous substances in electrical and electronic equipment

and that standards and/or technical specifications referenced overleaf have been applied:

EN60950-1:2005	Safety. Information technology equipment
EN62368-1:2014	Safety. Audio/video information and communication technology equipment
EN61000-6-4:2019	EMC. Generic emission standard for industrial environments
EN61000-6-2:2016	EMC. Generic immunity standard for industrial environments
For option T:	
EN50121-3-2:2016 + A1:2019	EMC. Railway apps. Rolling stock apparatus
EN50121-4:2016 + A1:2019	EMC. Railway apps. Signalling and telecommunications apparatus

CE marking year: **2020**; UKCA marking year: **2021**

### Notes:

For the fulfilment of this declaration the product must be used only for the aim that has been conceived, considering the limitations established in the instructions manual or datasheet.

L'Hospitalet de Llobregat, 18-02-2025

**Applicable values for the different sections of the norm EN50155: 2021**

4.4.1	Working altitude	Up to 2000m																																																																				
4.4.2	Ambient temperature	Class OT2 (-40 to 55°C): load <100% Class OT4 (-40 to 70°C): load <62.5%																																																																				
4.4.3	Switch-on extended operating temp.	ST1 (OTx +15°C, test cycle B)																																																																				
4.4.4	Rapid temperature variations	H1 (No requirements)																																																																				
4.4.5	Shocks and vibrations	According EN61373:2010 Category 1 class B																																																																				
4.4.6	EMC Electromagnetic Compatibility: EN50121-3-2:2017 EN50121-4:2016	<table border="1"> <thead> <tr> <th>Test</th> <th>Norm</th> <th>Port</th> <th>Frequency</th> <th>Limits</th> </tr> </thead> <tbody> <tr> <td rowspan="4">Radiated emissions</td> <td rowspan="4">IEC55016 :2019</td> <td rowspan="4">Case</td> <td>30MHz...230MHz</td> <td>40dB(µV/m) Qpk at 10m</td> </tr> <tr> <td>230MHz...1GHz</td> <td>47dB(µV/m) Qpk at 10m</td> </tr> <tr> <td>1...3GHz</td> <td>Do not apply</td> </tr> <tr> <td>3...6GHz</td> <td>Internal freq. &lt; 108MHz</td> </tr> <tr> <td rowspan="3">Conducted emissions</td> <td rowspan="3">IEC55016 :2019</td> <td rowspan="3">Input</td> <td>150kHz...500kHz</td> <td>EN50121-3-2: 99dB(µV) Qpk EN50121-4: 79dB(µV) Qpk, 66dB(µV) Av</td> </tr> <tr> <td>500kHz...30MHz</td> <td>EN50121-3-2: 93dB(µV) Qpk EN50121-4: 73dB(µV) Qpk, 60dB(µV) Av</td> </tr> <tr> <td></td> <td></td> </tr> </tbody> </table>				Test	Norm	Port	Frequency	Limits	Radiated emissions	IEC55016 :2019	Case	30MHz...230MHz	40dB(µV/m) Qpk at 10m	230MHz...1GHz	47dB(µV/m) Qpk at 10m	1...3GHz	Do not apply	3...6GHz	Internal freq. < 108MHz	Conducted emissions	IEC55016 :2019	Input	150kHz...500kHz	EN50121-3-2: 99dB(µV) Qpk EN50121-4: 79dB(µV) Qpk, 66dB(µV) Av	500kHz...30MHz	EN50121-3-2: 93dB(µV) Qpk EN50121-4: 73dB(µV) Qpk, 60dB(µV) Av																																										
		Test	Norm	Port	Frequency	Limits																																																																
		Radiated emissions	IEC55016 :2019	Case	30MHz...230MHz	40dB(µV/m) Qpk at 10m																																																																
					230MHz...1GHz	47dB(µV/m) Qpk at 10m																																																																
					1...3GHz	Do not apply																																																																
					3...6GHz	Internal freq. < 108MHz																																																																
		Conducted emissions	IEC55016 :2019	Input	150kHz...500kHz	EN50121-3-2: 99dB(µV) Qpk EN50121-4: 79dB(µV) Qpk, 66dB(µV) Av																																																																
					500kHz...30MHz	EN50121-3-2: 93dB(µV) Qpk EN50121-4: 73dB(µV) Qpk, 60dB(µV) Av																																																																
		<table border="1"> <thead> <tr> <th>Test</th> <th>Norm</th> <th>Port</th> <th>Severity</th> <th>Conditions</th> <th>P</th> </tr> </thead> <tbody> <tr> <td rowspan="2">Electrostatic discharge</td> <td rowspan="2">IEC61000-4-2 :2008</td> <td rowspan="2">Case</td> <td>±8kV</td> <td>Air (isolated parts)</td> <td rowspan="2">B</td> </tr> <tr> <td>±8kV</td> <td>Contact (conductive parts)</td> </tr> <tr> <td rowspan="4">Radiated high frequency</td> <td rowspan="4">IEC61000-4-3 :2020</td> <td rowspan="4">X/Y/Z Axis</td> <td>20V/m</td> <td>0.08...1.0GHz M. 80% 1kHz</td> <td rowspan="4">A</td> </tr> <tr> <td>10V/m</td> <td>1.4...2.1GHz M. 80% 1kHz</td> </tr> <tr> <td>5V/m</td> <td>2.0...2.7GHz M. 80% 1kHz</td> </tr> <tr> <td>3V/m</td> <td>5.1...6GHz M. 80% 1kHz</td> </tr> <tr> <td rowspan="4">Fast transients</td> <td rowspan="4">IEC61000-4-4 :2012</td> <td>Input</td> <td>±2kV</td> <td rowspan="4">Tr/Th: 5/50 ns</td> <td rowspan="4">A</td> </tr> <tr> <td>Output</td> <td>±2kV</td> </tr> <tr> <td>Signal</td> <td>±2kV</td> </tr> <tr> <td>PE</td> <td>±1kV</td> </tr> <tr> <td rowspan="2">Surge</td> <td rowspan="2">IEC61000-4-5 :2014</td> <td>Input L to L</td> <td>±1kV</td> <td rowspan="2">Tr/Th: 1.2/50µs</td> <td rowspan="2">B</td> </tr> <tr> <td>Input L to PE</td> <td>±2kV</td> </tr> <tr> <td rowspan="4">Conducted RF</td> <td rowspan="4">IEC61000-4-6 :2013</td> <td>Input</td> <td>10V</td> <td rowspan="4">0.15...80MHz M. 80% 1kHz</td> <td rowspan="4">A</td> </tr> <tr> <td>Output</td> <td>10V</td> </tr> <tr> <td>Signal</td> <td>10V</td> </tr> <tr> <td>PE</td> <td>10V</td> </tr> <tr> <td>Magnetic field</td> <td>IEC61000-4-8 :2009</td> <td>X/Y/Z Axis</td> <td>300A/m</td> <td>0Hz, 16.7Hz, 50/60Hz</td> <td>A</td> </tr> </tbody> </table>					Test	Norm	Port	Severity	Conditions	P	Electrostatic discharge	IEC61000-4-2 :2008	Case	±8kV	Air (isolated parts)	B	±8kV	Contact (conductive parts)	Radiated high frequency	IEC61000-4-3 :2020	X/Y/Z Axis	20V/m	0.08...1.0GHz M. 80% 1kHz	A	10V/m	1.4...2.1GHz M. 80% 1kHz	5V/m	2.0...2.7GHz M. 80% 1kHz	3V/m	5.1...6GHz M. 80% 1kHz	Fast transients	IEC61000-4-4 :2012	Input	±2kV	Tr/Th: 5/50 ns	A	Output	±2kV	Signal	±2kV	PE	±1kV	Surge	IEC61000-4-5 :2014	Input L to L	±1kV	Tr/Th: 1.2/50µs	B	Input L to PE	±2kV	Conducted RF	IEC61000-4-6 :2013	Input	10V	0.15...80MHz M. 80% 1kHz	A	Output	10V	Signal	10V	PE	10V	Magnetic field	IEC61000-4-8 :2009	X/Y/Z Axis	300A/m	0Hz, 16.7Hz, 50/60Hz	A
		Test	Norm	Port	Severity	Conditions	P																																																															
		Electrostatic discharge	IEC61000-4-2 :2008	Case	±8kV	Air (isolated parts)	B																																																															
±8kV	Contact (conductive parts)																																																																					
Radiated high frequency	IEC61000-4-3 :2020	X/Y/Z Axis	20V/m	0.08...1.0GHz M. 80% 1kHz	A																																																																	
			10V/m	1.4...2.1GHz M. 80% 1kHz																																																																		
			5V/m	2.0...2.7GHz M. 80% 1kHz																																																																		
			3V/m	5.1...6GHz M. 80% 1kHz																																																																		
Fast transients	IEC61000-4-4 :2012	Input	±2kV	Tr/Th: 5/50 ns	A																																																																	
		Output	±2kV																																																																			
		Signal	±2kV																																																																			
		PE	±1kV																																																																			
Surge	IEC61000-4-5 :2014	Input L to L	±1kV	Tr/Th: 1.2/50µs	B																																																																	
		Input L to PE	±2kV																																																																			
Conducted RF	IEC61000-4-6 :2013	Input	10V	0.15...80MHz M. 80% 1kHz	A																																																																	
		Output	10V																																																																			
		Signal	10V																																																																			
		PE	10V																																																																			
Magnetic field	IEC61000-4-8 :2009	X/Y/Z Axis	300A/m	0Hz, 16.7Hz, 50/60Hz	A																																																																	
<b>P</b> = Performance criteria, L= Line, PE= Protective Earth																																																																						
4.4.7	Relative humidity	Up to 95%																																																																				
10.7	Protective coating for PCB assemblies	Class PC2																																																																				
11.4	Fire behaviour requirements	EN45545-2:2020																																																																				
13.3	Tests list	<ul style="list-style-type: none"> <li>1 Visual Inspection</li> <li>2 Performance test</li> <li>3 Power supply test</li> <li>4 Insulation test</li> <li>5 Low temperature storage test</li> <li>6 Low temperature start-up test</li> <li>7 Dry heat test</li> <li>8 Cyclic damp heat test</li> <li>9 Salt mist test</li> <li>10 Enclosure protection test (IP code)</li> <li>11 EMC test</li> <li>12 Shocks and vibrations test</li> <li>13 Equipment stress screening test</li> <li>14 Rapid Temperature variation test</li> </ul>		<ul style="list-style-type: none"> <li>Routine</li> <li>Routine</li> <li>-</li> <li>Routine</li> <li>-</li> <li>Type</li> <li>Type</li> <li>Type</li> <li>-</li> <li>-</li> <li>Type</li> <li>Type</li> <li>40°C and load 100%</li> <li>Type</li> </ul>																																																																		

***Authorised, valued-added distributor***

Australia & New Zealand



**Powerbox Australia Pty Ltd**

Sydney Head Office  
4 Beaumont Road,  
Mt Kuring-Gai, NSW 2080  
Australia

 1800 251 380

 [sales@powerbox.com.au](mailto:sales@powerbox.com.au)

 [powerbox.com.au](http://powerbox.com.au)

**Powerbox Pacific Ltd**

New Zealand Sales Office  
1a Henry Rose Place,  
Albany, Auckland  
New Zealand 0632

 09 4158 320

 [sales@powerbox.co.nz](mailto:sales@powerbox.co.nz)

 [powerbox.co.nz](http://powerbox.co.nz)