



CQB75W SERIES

75 WATT 4:1 INPUT DC-DC CONVERTERS SINGLE OUTPUT



FEATURES

- * 39.6-75W Isolated Output
- * Efficiency to 87%
- * Fixed Switching Frequency
- * 4:1 Input Range
- * Regulated Outputs
- * Continuous Short Circuit Protection
- * Industry Standard Quarter-Brick Package
- * UL60950-1 2nd Approval
- * Safety Meets IEC/EN/UL 62368-1



MODEL NUMBER	INPUT VOLTAGE	OUTPUT VOLTAGE	OUTPUT CURRENT		INPUT CURRENT		% EFF.	CAPACITOR LOAD MAX.
			MIN.	MAX.	NO LOAD	FULL LOAD		
CQB75W-24S3V3	9-36 VDC	3.3 VDC	0 mA	12 A	50 mA	2037 mA	81	12000uF
CQB75W-24S05	9-36 VDC	5.0 VDC	0 mA	12 A	50 mA	2976 mA	84	12000uF
CQB75W-24S12	9-36 VDC	12 VDC	0 mA	6.25 A	50 mA	3634 mA	86	6250uF
CQB75W-24S15	9-36 VDC	15 VDC	0 mA	5 A	50 mA	3634 mA	86	4400uF
CQB75W-24S24	9-36 VDC	24 VDC	0 mA	3.12 A	50 mA	3628 mA	86	1500uF
CQB75W-48S3V3	18-75 VDC	3.3 VDC	0 mA	12 A	30 mA	1006 mA	82	12000uF
CQB75W-48S05	18-75 VDC	5.0 VDC	0 mA	12 A	30 mA	1471 mA	85	12000uF
CQB75W-48S12	18-75 VDC	12 VDC	0 mA	6.25 A	30 mA	1817 mA	86	6250uF
CQB75W-48S15	18-75 VDC	15 VDC	0 mA	5 A	30 mA	1796 mA	87	4400uF
CQB75W-48S24	18-75 VDC	24 VDC	0 mA	3.12 A	30 mA	1796 mA	87	1500uF

NOTE: 1. Nominal Input Voltage 24, 48VDC

SPECIFICATIONS

All Specifications Typical at Nominal Line, Full Load, and 25°C Unless Otherwise Noted

INPUT SPECIFICATIONS:

Input Voltage Range	24V	9-36V
	48V	18-75V
Input Surge Voltage (100ms max.)	24V	50Vdc max.
	48V	100Vdc max.
Under Voltage Lockout	24Vin power up	8.8V
	24Vin power down	8.0V
	48Vin power up	17V
	48Vin power down	16V
Positive Logic Remote On/Off (note 4&5)		
Input Filter		PI Type

OUTPUT SPECIFICATIONS:

Voltage Accuracy:	±1.0% max.
	24(48)S33 ±1.5% max.
Transient Response :75% to 100% Step Load Change	
Error Band	±5% Vout
Recover Time	<500us
External Trim Adj. Range	±10%
Ripple & Noise, 20MHz BW (note3)	
3.3V & 5V	40mV RMS, max.
	100mV pk-pk, max.
12V & 15V	60mV RMS, max.
	150mV pk-pk, max.
24V	100mV RMS, max.
	240mV pk-pk, max.
Temperature Coefficient	±0.03%/°C max.
Short Circuit Protection	Continuous
Line Regulation (note1)	±0.2% max.
Load Regulation (note2)	±0.2% max.
Over Voltage Protection Trip Range, %Vo Nom.	115-140%
Current Limit	110%-150% Nominal Output
Start up Time	20ms typ.

CASE QB

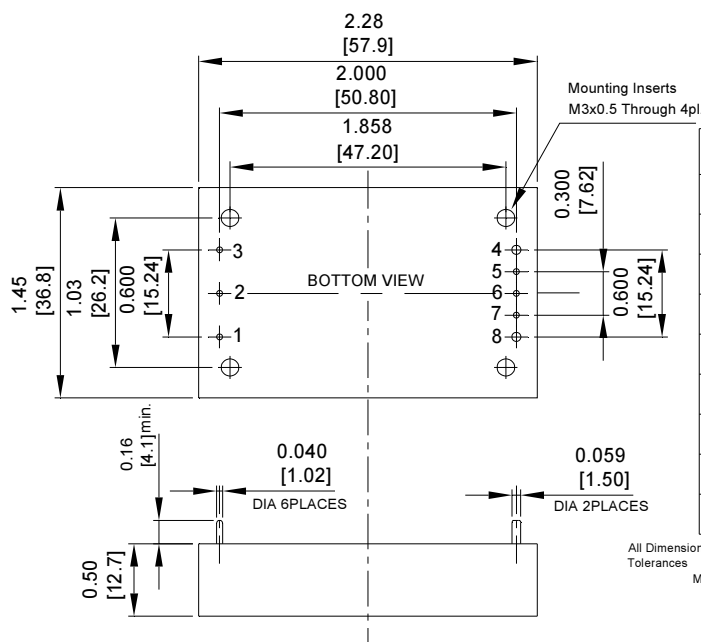

GENERAL SPECIFICATIONS:

Efficiency		See Table
Isolation Voltage	Input/Output	1500VDC min.
	Input/Case	1500VDC min.
	Output/Case	1500VDC min.
Isolation Resistance		10 ⁷ Ohm min.
Isolation Capacitance		1000pF typ.
Switching Frequency		300KHz typ.
Operating Case Temperature		-40°C to 100°C
Storage Temperature		-55°C to +105°C
Humidity		95% RH max. Non Condensing
MTBF	MIL-HDBK-217F, GB, 25°C, Full Load	850Khrs typ.
Thermal Shutdown, Case Temp.		105°C typ.
Dimensions		1.45 x 2.28 x 0.50 Inches(36.8 x 57.9 x 12.7 mm)
Case Material		Aluminum Base-plate with Plastic Case
Weight		63g

NOTE:

1. Measured from high line to low line.
2. Measured from full load to zero load.
3. Output ripple and noise measured with 10uF tantalum and 1uF ceramic capacitor across output.
4. Logic Compatibility
 - Module on >3.5Vdc to 75Vdc or Open Circuit
 - Module off 0 to < 1.8Vdc
5. Suffix "N" to the model number with negative logic remote on/off
 - Module on 0 to < 1.8Vdc
 - Module off >3.5Vdc to 75Vdc or open circuit
6. Suffix "-C" to the model number with clear mounting insert (3.1mm DIA.).

External Output Trim

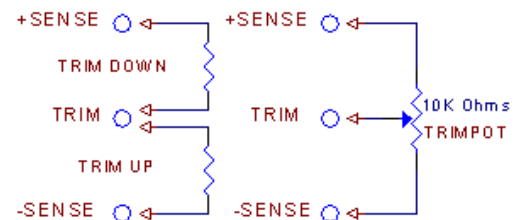

Authorised, valued-added distributor

Australia & New Zealand



Powerbox Australia Pty Ltd

Sydney Head Office
4 Beaumont Road,
Mt Kuring-Gai, NSW 2080
Australia



1800 251 380



sales@powerbox.com.au



powerbox.com.au

Powerbox Pacific Ltd

New Zealand Sales Office
1a Henry Rose Place,
Albany, Auckland
New Zealand 0632



09 4158 320



sales@powerbox.co.nz



powerbox.co.nz