

# AEA-series

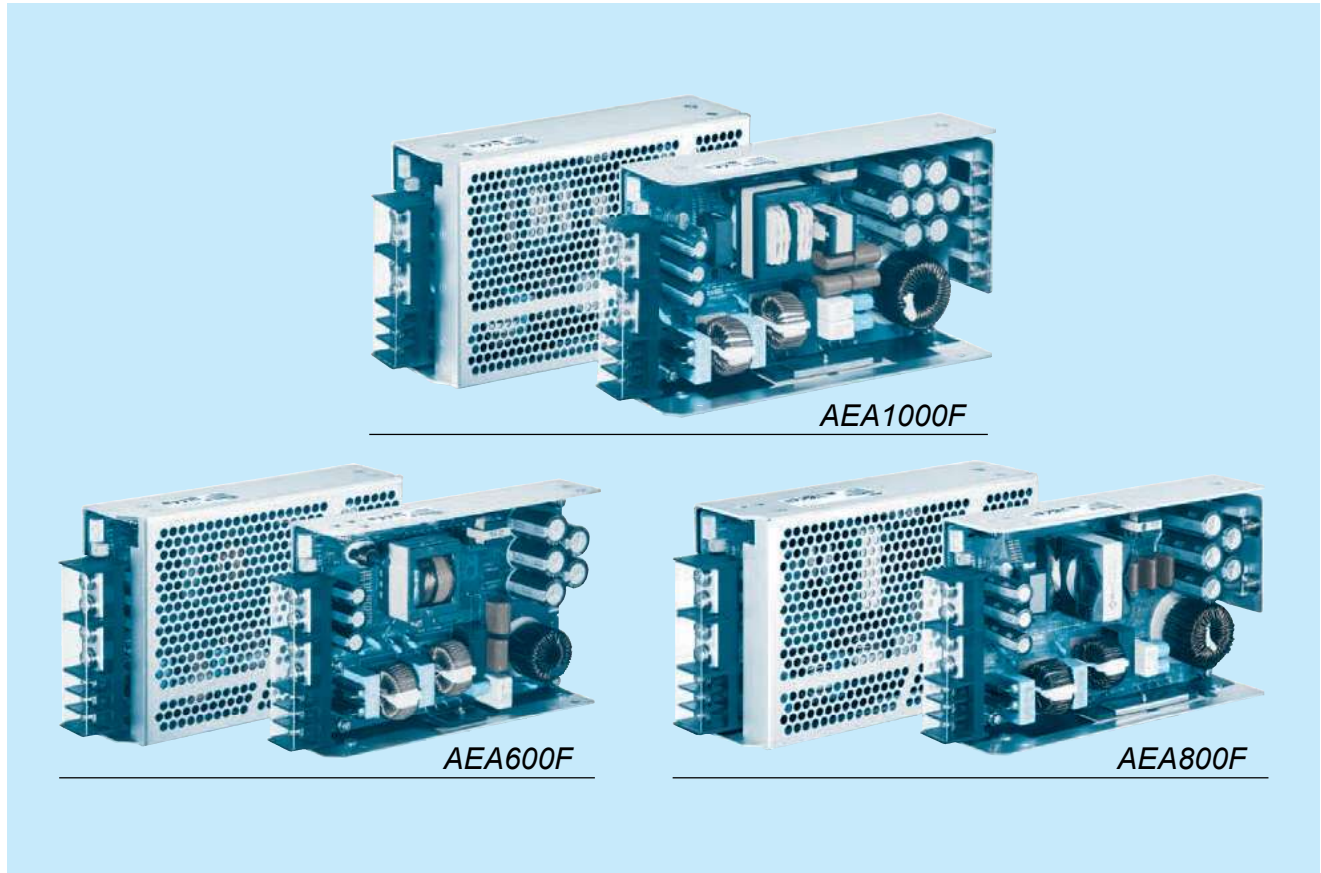

## Feature

- High power & peak power
- High efficiency
- Low profile (41mm, 1.61 inch = meet to 1U height)
- For medical electric equipment (ANSI/AAMI ES60601, EN60601-1 3rd, IEC60601-1-2 4th Ed.)
- Suitable for BF application (Output-FG : 1MOPP, Input-Output : 2MOPP)
- OVC III (according to EN62477-1)
- Complies with SEMI F47 (Refer to Instruction Manual)
- UL508 (Optional)

## Safety agency approval

- UL62368-1, ANSI/AAMI ES60601-1
- C-UL (CAN/CSA62368-1, CAN/CSA60601-1)
- EN62368-1, EN60601-1 3rd
- Complies with IEC60601-1-2 4th Ed. , IEC60335-1(AEA600F)
- EN62477-1 (OVC III)
- UL508 (Optional)

## 5-year warranty (Refer to Instruction Manual)

## CE marking

- Low Voltage Directive
- RoHS Directive

## UKCA marking

- Electrical Equipment Safety Regulations
- RoHS Regulations

## EMI

- Complies with FCC-B, CISPR11-B, CISPR32-B, EN55011-B, EN55032-B, VCCI-B

## EMS Compliance : EN61204-3, EN61000-6-2 IEC60601-1-2(2014), EN60601-1-2(2015)

- EN61000-4-2
- EN61000-4-3
- EN61000-4-4
- EN61000-4-5
- EN61000-4-6
- EN61000-4-8
- EN61000-4-11

# AEA600F

AE A 600 F -□□ -□  
 ① ② ③ ④ ⑤ ⑥



Example recommended EMI/EMC filter  
**EAC-20-472**



High voltage pulse noise type : EAP series  
 Low leakage current type : EAM series  
 \*Use of an EMI/EMC filter is recommended when a power supply is connected with several devices so that additional filtering is necessary.  
 \*Make sure that your final application will meet the required EMC standard by measuring the EMI level of the power supply used together with an EMI/EMC filter.

- ① Series name
  - ② Single output
  - ③ Output wattage
  - ④ Universal input
  - ⑤ Output voltage
  - ⑥ Optional \*1
  - C : with Coating
  - N : with cover
  - T : Vertical terminal block
  - J : Connector type
  - R3 : with Subfeatures (5V1A AUX, 12V1A AUX Remote ON/OFF, Alarm)
  - I4 : with MODBUS interface and Subfeatures (5V1A AUX, 12V1A AUX Remote ON/OFF, Alarm)
  - T5 : UL508 (Except 32V)
  - P5 : shutdown type overcurrent protection
- For option details, refer to instruction manual 6.1.

Please refer to derating curve, because the rated load current depends on cooling method that is convection cooling or forced air.  
 \*Make sure necessary tests will be carried out on your end equipment with the power supply installed in accordance with any required EMC/EMI regulations.

MODEL	AEA600F-24	AEA600F-32	AEA600F-36	AEA600F-48
MAX OUTPUT WATTAGE[W]	600	601	601.2	600
DC OUTPUT (forced air)	ACIN 100V	24V 20.0 (Peak 42.0) A	32V 15.0 (Peak 31.5) A	36V 13.4 (Peak 28.0) A
	ACIN 230V	24V 25.0 (Peak 52.5) A	32V 18.8 (Peak 39.4) A	36V 16.7 (Peak 35.0) A

## SPECIFICATIONS

MODEL	AEA600F-24	AEA600F-32	AEA600F-36	AEA600F-48
VOLTAGE[V]	AC85 - 264 1 φ (Output derating is required at AC85V - 170V. See "Derating")			
CURRENT[A]	ACIN 100V	5.7typ (Io=20A)	5.7typ (Io=15.0A)	5.7typ (Io=13.4A)
	ACIN 230V	2.9typ (Io=25A)	2.9typ (Io=18.8A)	2.9typ (Io=16.7A)
FREQUENCY[Hz]	50/60 (45 - 66)			
EFFICIENCY[%]	ACIN 100V	92.0%typ (Io=20A)	92.0%typ (Io=15.0A)	92.0%typ (Io=13.4A)
	ACIN 230V	94.5%typ (Io=25A)	95.0%typ (Io=18.8A)	95.0%typ (Io=16.7A)
POWER FACTOR	ACIN 100V	0.98typ (Io=20A)	0.98typ (Io=15.0A)	0.98typ (Io=13.4A)
	ACIN 230V	0.95typ (Io=25A)	0.95typ (Io=18.8A)	0.95typ (Io=16.7A)
INRUSH CURRENT[A] *2	ACIN 100V	20/40typ (Io=20A)	20/40typ (Io=15.0A)	20/40typ (Io=13.4A)
	ACIN 230V	40/40typ (Io=25A)	40/40typ (Io=18.8A)	40/40typ (Io=16.7A)
LEAKAGE CURRENT[ma]	0.3max (ACIN 240V 60Hz, Io=100%, According to IEC60601-1)			
VOLTAGE[V]	24	32	36	48
CURRENT[A]	ACIN 100V	14.0 (Peak 42.0) convection	10.5 (Peak 31.5) convection	9.4 (Peak 28.0) convection
		20.0 (Peak 42.0) forced air	15.0 (Peak 31.5) forced air	13.4 (Peak 28.0) forced air
		17.5 (Peak 52.5) convection	13.2 (Peak 39.4) convection	11.7 (Peak 35.0) convection
ACIN 230V	25.0 (Peak 52.5) forced air	18.8 (Peak 39.4) forced air	16.7 (Peak 35.0) forced air	12.5 (Peak 26.3) forced air
	144max	144max	144max	192max
	200max	200max	200max	200max
RIPPLE[mVp-p] *3	0 to +50°C	200max	200max	200max
	-20 to 0°C	200max	200max	200max
RIPPLE NOISE[mVp-p]*3	0 to +50°C	150max	270max	230max
	-20 to 0°C	230max	350max	350max
TEMPERATURE REGULATION[mV]	0 to +50°C	240max	360max	360max
DRIFT[mV] *4	96max	144max	144max	192max
START-UP[ms]	550typ (ACIN 100V/230V) 750typ (ACIN 85V-264V)			
HOLD-UP[ms]	20typ (ACIN 230V, Io=100%)			
OUTPUT VOLTAGE ADJUSTMENT RANGE[V]	21.6 to 26.4	28.8 to 35.2	32.4 to 39.6	43.2 to 52.8
OUTPUT VOLTAGE SETTING[V]	23.5 to 24.5	31.0 to 33.0	35.0 to 37.0	47.0 to 49.0
OVERCURRENT PROTECTION	Works over 101% of peak current and recovers automatically *5			
OVERVOLTAGE PROTECTION[V]	30 to 33.6	43.0 to 48.4	45 to 50.4	60 to 69.6
ALARM	Optional (Input voltage alarm : PR, Output voltage alarm : PG)			
REMOTE ON/OFF	Optional			
AUX1	Optional (12V1A forced air)			
AUX2	Optional (5V1A forced air)			
INPUT-OUTPUT · PR · PG · RC · AUX *6	AC4,000V 1minute, Cutoff current = 10mA, DC500V 50MΩ min (At Room Temperature) 2MOPP			
INPUT-FG	AC2,000V 1minute, Cutoff current = 10mA, DC500V 50MΩ min (At Room Temperature) 1MOPP			
OUTPUT · PR · PG · RC · AUX-FG *6	AC1,500V 1minute, Cutoff current = 10mA, DC500V 50MΩ min (At Room Temperature) 1MOPP			
OUTPUT · AUX1-PR · PG · RC · AUX2 *6	AC100V 1minute, Cutoff current = 25mA, DC100V 10MΩ min (At Room Temperature)			
OPERATING TEMP., HUMID. AND ALTITUDE	-20 to +70°C, 20 - 90%RH (Non condensing), 5,000m (16,500feet) max			
STORAGE TEMP., HUMID. AND ALTITUDE	-20 to +75°C, 20 - 90%RH (Non condensing), 9,000m (30,000feet) max			
VIBRATION	10 - 55Hz, 19.6m/s <sup>2</sup> (2G), 3minutes period, 60minutes each along X, Y and Z axis			
IMPACT	196.1m/s <sup>2</sup> (20G), 11ms, once each X, Y and Z axis			
AGENCY APPROVALS	UL62368-1, AANSI/AAMI ES 60601-1, C-UL (equivalent to CAN/CSA-C22.2 No.62368-1, CAN/CSA-C22.2 No.60601-1) EN62368-1, EN60601-1 3rd, EN62477-1 (OVCI), UL508 (Optional, Except 32V), Complies with IEC60601-1-2 4th Ed., IEC60335-1(Except 32V)			
CONDUCTED NOISE	Complies with FCC Part15 classB, VCCI-B, CISPR32-B, EN55011-B, EN55032-B			
HARMONIC ATTENUATOR *7	Complies with IEC61000-3-2 (Class A)			
CASE SIZE/WEIGHT	41x127x186mm [1.61x5x7.32 inches] (WxHxD) (without terminal block) / 1.0kg max			
COOLING METHOD	Convection/Forced air			

\*1 The listed options may affect the published standard specifications. Please contact us for detailed product specification

\*2 The current of input surge to a built-in EMI/EMS Filter (0.2ms or less) is excluded.

\*3 Measured by 20MHz oscilloscope or Ripple-Noise meter (equivalent to KEISOKUGIKEN:RM104). Please refer to the instruction manual 1.8.

\*4 Drift is the change in DC output for an eight hours period after a half-hour warm-up at 25°C

\*5 When the overcurrent protection continues, the output may be shut down.

\*6 Applicable when AUX and remote control (optional) is added.

\*7 Please contact us about another class.

\* Sound noise may be generated by power supply in case of pulse load.



# AEA800F

AE A 800 F -□□ -□  
 ① ② ③ ④ ⑤ ⑥



Example recommended EMI/EMC filter  
**NAC-30-472**

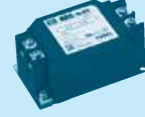

High voltage pulse noise type : NAP series  
 Low leakage current type : NAM series  
 \*Use of an EMI/EMC filter is recommended when a power supply is connected with several devices so that additional filtering is necessary.  
 \*Make sure that your final application will meet the required EMC standard by measuring the EMI level of the power supply used together with an EMI/EMC filter.

- ① Series name
  - ② Single output
  - ③ Output wattage
  - ④ Universal input
  - ⑤ Output voltage
  - ⑥ Optional \*1
  - C : with Coating
  - N : with cover
  - T : Vertical terminal block
  - J : Connector type
  - R3 : with Subfeatures (5V1A AUX, 12V1A AUX Remote ON/OFF, Alarm)
  - I4 : with MODBUS interface and Subfeatures (5V1A AUX, 12V1A AUX Remote ON/OFF, Alarm)
  - T5 : UL508 (Except 30V)
  - P5 : shutdown type overcurrent protection
- For option details, refer to instruction manual 6.1.

Please refer to derating curve, because the rated load current depends on cooling method that is convection cooling or forced air.  
 \*Make sure necessary tests will be carried out on your end equipment with the power supply installed in accordance with any required EMC/EMI regulations.

MODEL	AEA800F-24	AEA800F-30	AEA800F-36	AEA800F-48
<b>MAX OUTPUT WATTAGE[W]</b>	<b>816</b>	<b>816</b>	<b>817</b>	<b>816</b>
<b>DC OUTPUT (forced air)</b>	ACIN 100V <b>24V 25.5 (Peak 54.3) A</b>	<b>30V 20.4 (Peak 43.5) A</b>	<b>36V 17.0 (Peak 36.3) A</b>	<b>48V 12.7 (Peak 27.2) A</b>
	ACIN 230V <b>24V 34.0 (Peak 72.5) A</b>	<b>30V 27.2 (Peak 58.0) A</b>	<b>36V 22.7 (Peak 48.4) A</b>	<b>48V 17.0 (Peak 36.3) A</b>

## SPECIFICATIONS

MODEL	AEA800F-24	AEA800F-30	AEA800F-36	AEA800F-48	
<b>VOLTAGE[V]</b>	AC85 - 264 1φ (Output derating is required at AC85 - 170V. See "Derating")				
<b>CURRENT[A]</b>	ACIN 100V 6.6typ (Io=25.5A)	6.6typ (Io=20.4A)	6.6typ (Io=17.0A)	6.6typ (Io=12.7A)	
	ACIN 230V 3.7typ (Io=34.0A)	3.7typ (Io=27.2A)	3.7typ (Io=22.7A)	3.7typ (Io=17.0A)	
<b>FREQUENCY[Hz]</b>	50/60 (45 - 66)				
<b>EFFICIENCY[%]</b>	ACIN 100V 92.5typ (Io=25.5A)	92.5typ (Io=20.4A)	92.5typ (Io=17.0A)	92.5typ (Io=12.7A)	
	ACIN 230V 95.0typ (Io=34.0A)	95.0typ (Io=27.2A)	95.5typ (Io=22.7A)	95.5typ (Io=17.0A)	
<b>POWER FACTOR</b>	ACIN 100V 0.98typ (Io=25.5A)	0.98typ (Io=20.4A)	0.98typ (Io=17.0A)	0.98typ (Io=12.7A)	
	ACIN 230V 0.95typ (Io=34.0A)	0.95typ (Io=27.2A)	0.95typ (Io=22.7A)	0.95typ (Io=17.0A)	
<b>INRUSH CURRENT[A] *2</b>	ACIN 100V 20/40typ (Io=25.5A)	20/40typ (Io=20.4A)	20/40typ (Io=17.0A)	20/40typ (Io=12.7A)	
	ACIN 230V 40/40typ (Io=34.0A)	40/40typ (Io=27.2A)	40/40typ (Io=22.7A)	40/40typ (Io=17.0A)	
<b>LEAKAGE CURRENT[ma]</b>	0.3max (ACIN 240V 60Hz, Io=100%, According to IEC60601-1)				
<b>OUTPUT</b>	<b>VOLTAGE[V]</b>	24	30	36	48
	<b>CURRENT[A]</b>	ACIN 100V 17.6 (Peak 54.3) convection	14.1 (Peak 43.5) convection	11.7 (Peak 36.3) convection	8.8 (Peak 27.2) convection
		25.5 (Peak 54.3) forced air	20.4 (Peak 43.5) forced air	17.0 (Peak 36.3) forced air	12.7 (Peak 27.2) forced air
		ACIN 230V 23.5 (Peak 72.5) convection	18.8 (Peak 58.0) convection	15.7 (Peak 48.4) convection	11.8 (Peak 36.3) convection
	34.0 (Peak 72.5) forced air	27.2 (Peak 58.0) forced air	22.7 (Peak 48.4) forced air	17.0 (Peak 36.3) forced air	
	<b>LINE REGULATION[mV]</b>	96max	120max	144max	192max
	<b>LOAD REGULATION[mV]</b>	150max	200max	240max	300max
	<b>RIPPLE[mVp-p] *3</b>	0 to +50°C 120max	200max	200max	250max
		-20 to 0°C 230max	300max	300max	400max
	<b>RIPPLE NOISE[mVp-p]*3</b>	0 to +50°C 150max	230max	230max	300max
		-20 to 0°C 250max	350max	350max	550max
	<b>TEMPERATURE REGULATION[mV]</b>	0 to +50°C 240max	300max	360max	480max
	<b>DRIFT[mV] *4</b>	96max	120max	144max	192max
<b>START-UP[ms]</b>	550typ (ACIN 100V/230V) 750typ (ACIN 85V-264V)				
<b>HOLD-UP[ms]</b>	20typ (ACIN 230V, Io=100%)				
<b>OUTPUT VOLTAGE ADJUSTMENT RANGE[V]</b>	21.6 to 26.4	27.0 to 33.0	32.4 to 39.6	43.2 to 52.8	
<b>OUTPUT VOLTAGE SETTING[V]</b>	23.5 to 24.5	29.0 to 31.0	35.0 to 37.0	47.0 to 49.0	
<b>PROTECTION CIRCUIT AND OTHERS</b>	<b>OVERCURRENT PROTECTION</b>	Works over 101% of peak current and recovers automatically *5			
	<b>OVERVOLTAGE PROTECTION[V]</b>	30 to 33.6	37.5 to 42.0	45 to 50.4	60 to 69.6
	<b>ALARM</b>	Optional (Input voltage alarm : PR, Output voltage alarm : PG)			
	<b>REMOTE ON/OFF</b>	Optional			
	<b>AUX1</b>	Optional (12V1A forced air)			
<b>ISOLATION</b>	<b>INPUT-OUTPUT · PR · PG · RC · AUX *6</b>	AC4,000V 1minute, Cutoff current = 10mA, DC500V 50MΩ min (At Room Temperature) 2MOPP			
	<b>INPUT-FG</b>	AC2,000V 1minute, Cutoff current = 10mA, DC500V 50MΩ min (At Room Temperature) 1MOPP			
	<b>OUTPUT · PR · PG · RC · AUX-FG *6</b>	AC1,500V 1minute, Cutoff current = 10mA, DC500V 50MΩ min (At Room Temperature) 1MOPP			
	<b>OUTPUT · AUX1-PR · PG · RC · AUX2 *6</b>	AC100V 1minute, Cutoff current = 25mA, DC100V 10MΩ min (At Room Temperature)			
<b>ENVIRONMENT</b>	<b>OPERATING TEMP., HUMID. AND ALTITUDE</b>	-20 to +70°C, 20 - 90%RH (Non condensing), 5,000m (16,500feet) max			
	<b>STORAGE TEMP., HUMID. AND ALTITUDE</b>	-20 to +75°C, 20 - 90%RH (Non condensing), 9,000m (30,000feet) max			
	<b>VIBRATION</b>	10 - 55Hz, 19.6m/s <sup>2</sup> (2G), 3minutes period, 60minutes each along X, Y and Z axis			
	<b>IMPACT</b>	196.1m/s <sup>2</sup> (20G), 11ms, once each X, Y and Z axis			
<b>SAFETY AND NOISE REGULATIONS</b>	<b>AGENCY APPROVALS</b>	UL62368-1, ANSI/AAMI ES 60601-1, C-UL (equivalent to CAN/CSA-C22.2 No.62368-1, CAN/CSA-C22.2 No.60601-1) EN62368-1, EN60601-1 3rd, EN62477-1 (OVCI), UL508 (Optional), Complies with IEC60601-1-2 4th Ed.			
	<b>CONDUCTED NOISE</b>	Complies with FCC Part15 classB, VCCI-B, CISPR32-B, EN55011-B, EN55032-B			
	<b>HARMONIC ATTENUATOR *7</b>	Complies with IEC61000-3-2 (Class A)			
<b>OTHERS</b>	<b>CASE SIZE/WEIGHT</b>	50x127x203.2mm [1.97x5x8 inches] (WxHxD) (without terminal block) / 1.3kg max			
	<b>COOLING METHOD</b>	Convection/Forced air			

\*1 The listed options may affect the published standard specifications. Please contact us for detailed product specification

\*2 The current of input surge to a built-in EMI/EMS Filter (0.2ms or less) is excluded.

\*3 Measured by 20MHz oscilloscope or Ripple-Noise meter (equivalent to KEISOKUGIKEN:RM104). Please refer to the instruction manual 1.8.

\*4 Drift is the change in DC output for an eight hours period after a half-hour warm-up at 25°C

\*5 When the overcurrent protection continues, the output may be shut down.

\*6 Applicable when AUX and remote control (optional) is added.

\*7 Please contact us about another class.

\* Sound noise may be generated by power supply in case of pulse load.

Features

- High power & peak power
- High efficiency : 95% typ (Input Voltage 230V, Output Voltage 24V)
- Low profile (50mm, 1.97inch)
- For medical electric equipment (ANSI/AAMI ES60601, EN60601-1 3rd, IEC60601-1-2 4th Ed.)
- Suitable for BF application (Output-FG : 1MOPP, Input-Output : 2MOPP)
- OVC III (according to EN62477-1)
- Complies with SEMI F47 (Refer to Instruction Manual)
- With AUX1 (12V 1A), AUX2 (5V 1A) (Optional)

Block diagram

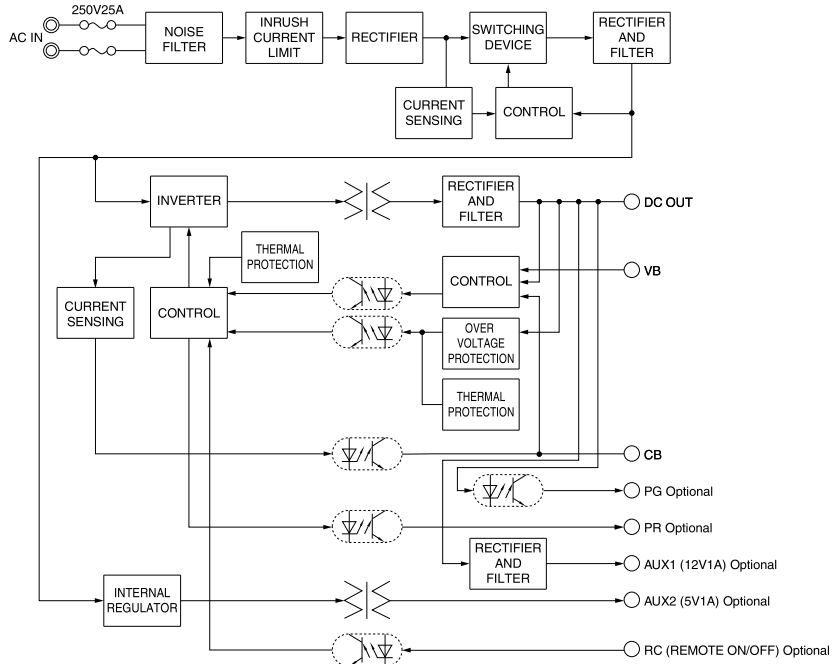

External view

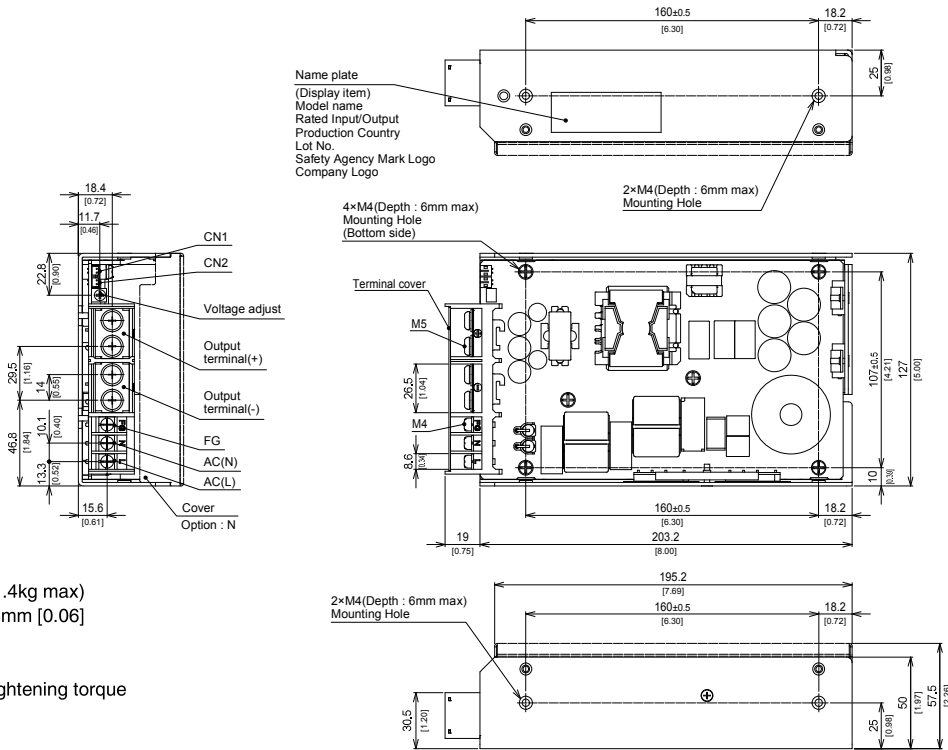

Option  
 -N : with CoverCover material Aluminum

- \* Dimensions in mm [inch]
- \* Tolerance : ±1 [±0.04]
- \* Weight : 1.3kg max (with Cover : 1.4kg max)
- \* PCB Material/thickness : FR-4/1.6mm [0.06]
- \* Chassis Material : Aluminum
- \* Mounting torque : 1.2N · m max
- \* Input and output terminal screw tightening torque  
 M4 1.6N · m max  
 M5 2.5N · m max
- \* Please connect safety ground to mounting hole on the unit.

# AEA1000F

AE A 1000 F -□□ -□

① ② ③ ④ ⑤ ⑥



Example recommended EMI/EMC filter  
NAC-30-472



High voltage pulse noise type : NAP series  
Low leakage current type : NAM series  
\*Use of an EMI/EMC filter is recommended when a power supply is connected with several devices so that additional filtering is necessary.  
\*Make sure that your final application will meet the required EMC standard by measuring the EMI level of the power supply used together with an EMI/EMC filter.

- ① Series name
  - ② Single output
  - ③ Output wattage
  - ④ Universal input
  - ⑤ Output voltage
  - ⑥ Optional \*1
  - C : with Coating
  - N : with cover
  - T : Vertical terminal block
  - J : Connector type
  - R3 : with Subfeatures (5V1A AUX, 12V1A AUX Remote ON/OFF, Alarm)
  - I4 : with MODBUS interface and Subfeatures (5V1A AUX, 12V1A AUX Remote ON/OFF, Alarm)
  - T5 : UL508
  - P5 : shutdown type overcurrent protection
- For option details, refer to instruction manual 6.1.

Please refer to derating curve, because the rated load current depends on cooling method that is convection cooling or forced air.  
\*Make sure necessary tests will be carried out on your end equipment with the power supply installed in accordance with any required EMC/EMI regulations.

MODEL	AEA1000F-24	AEA1000F-36	AEA1000F-48
MAX OUTPUT WATTAGE[W]	1,008	1,008	1,008
DC OUTPUT (forced air)	ACIN 100V 24V 31.5 (Peak 75.0) A	36V 21.0 (Peak 50.0) A	48V 15.8 (Peak 37.5) A
	ACIN 230V 24V 42.0 (Peak 100.0) A	36V 28.0 (Peak 66.7) A	48V 21.0 (Peak 50.0) A

## SPECIFICATIONS

MODEL	AEA1000F-24	AEA1000F-36	AEA1000F-48	
VOLTAGE[V]	AC85 - 264 1φ (Output derating is required at AC85V - 170V. See "Derating")			
CURRENT[A]	ACIN 100V	8.4typ (Io=31.5A)	8.4typ (Io=21.0A)	8.4typ (Io=15.8A)
	ACIN 230V	4.9typ (Io=42.0A)	4.9typ (Io=28.0A)	4.9typ (Io=21.0A)
FREQUENCY[Hz]	50/60 (45 - 66)			
EFFICIENCY[%]	ACIN 100V	92.0typ (Io=31.5A)	92.0typ (Io=21.0A)	92.0typ (Io=15.8A)
	ACIN 230V	95.0typ (Io=42.0A)	95.0typ (Io=28.0A)	95.0typ (Io=21.0A)
POWER FACTOR	ACIN 100V	0.98typ (Io=31.5A)	0.98typ (Io=21.0A)	0.98typ (Io=15.8A)
	ACIN 230V	0.95typ (Io=42.0A)	0.95typ (Io=28.0A)	0.95typ (Io=21.0A)
INRUSH CURRENT[A] *2	ACIN 100V	20/40typ (Io=31.5A)	20/40typ (Io=21.0A)	20/40typ (Io=15.8A)
	ACIN 230V	40/40typ (Io=42.0A)	40/40typ (Io=28.0A)	40/40typ (Io=21.0A)
LEAKAGE CURRENT[ma]	0.3max (ACIN 240V 60Hz, Io=100%, According to IEC60601-1)			
VOLTAGE[V]	24	36	48	
CURRENT[A]	ACIN 100V	22.5 (Peak 75.0) convection	15.0 (Peak 50.0) convection	11.3 (Peak 37.5) convection
		31.5 (Peak 75.0) forced air	21.0 (Peak 50.0) forced air	15.8 (Peak 37.5) forced air
	ACIN 230V	30.0 (Peak 100.0) convection	20.0 (Peak 66.7) convection	15.0 (Peak 50.0) convection
		42.0 (Peak 100.0) forced air	28.0 (Peak 66.7) forced air	21.0 (Peak 50.0) forced air
LINE REGULATION[mV]	96max	144max	192max	
LOAD REGULATION[mV]	150max	240max	300max	
RIPPLE[mVp-p] *3	0 to +50°C	150max	230max	300max
	-20 to 0°C	230max	350max	450max
	Io=0 to 30%	500max	550max	600max
RIPPLE NOISE[mVp-p] *3	0 to +50°C	300max	350max	400max
	-20 to 0°C	450max	530max	600max
	Io=0 to 30%	700max	750max	800max
TEMPERATURE REGULATION[mV]	0 to +50°C	240max	360max	480max
DRIFT[mV] *4	96max	144max	192max	
START-UP[ms]	550typ (ACIN 100V/230V) 750typ (ACIN 85V-264V)			
HOLD-UP[ms]	20typ (ACIN 230V, Io=100%)			
OUTPUT VOLTAGE ADJUSTMENT RANGE[V]	22.8 to 26.4	34.2 to 39.6	45.6 to 52.8	
OUTPUT VOLTAGE SETTING[V]	23.5 to 24.5	35.0 to 37.0	47.0 to 49.0	
OVERCURRENT PROTECTION	Works over 101% of peak current and recovers automatically *5			
OVERVOLTAGE PROTECTION[V]	30 to 33.6	45 to 50.4	60 to 69.6	
ALARM	Optional (Input voltage alarm : PR, Output voltage alarm : PG)			
REMOTE ON/OFF	Optional			
AUX1	Optional (12V1A forced air)			
AUX2	Optional (5V1A forced air)			
ISOLATION	INPUT-OUTPUT · PR · PG · RC · AUX *6	AC4,000V 1minute, Cutoff current = 10mA, DC500V 50MΩ min (At Room Temperature) 2MOPP		
	INPUT-FG	AC2,000V 1minute, Cutoff current = 10mA, DC500V 50MΩ min (At Room Temperature) 1MOPP		
	OUTPUT · PR · PG · RC · AUX-FG *6	AC1,500V 1minute, Cutoff current = 10mA, DC500V 50MΩ min (At Room Temperature) 1MOPP		
	OUTPUT · AUX1-PR · PG · RC · AUX2 *6	AC100V 1minute, Cutoff current = 25mA, DC100V 10MΩ min (At Room Temperature)		
ENVIRONMENT	OPERATING TEMP., HUMID. AND ALTITUDE	-20 to +70°C, 20 - 90%RH (Non condensing), 5,000m (16,500feet) max		
	STORAGE TEMP., HUMID. AND ALTITUDE	-20 to +75°C, 20 - 90%RH (Non condensing), 9,000m (30,000feet) max		
	VIBRATION	10 - 55Hz, 19.6m/s <sup>2</sup> (2G), 3minutes period, 60minutes each along X, Y and Z axis		
	IMPACT	196.1m/s <sup>2</sup> (20G), 11ms, once each X, Y and Z axis		
SAFETY AND NOISE REGULATIONS	AGENCY APPROVALS	UL62368-1, ANSI/AAMI ES 60601-1, C-UL (equivalent to CAN/CSA-C22.2 No.62368-1, CAN/CSA-C22.2 No.60601-1) EN62368-1, EN60601-1 3rd, EN62477-1 (OVCI), UL508 (Optional), Complies with IEC60601-1-2 4th Ed.		
	CONDUCTED NOISE	Complies with FCC Part15 classB, VCCI-B, CISPR32-B, EN55011-B, EN55032-B		
	HARMONIC ATTENUATOR *7	Complies with IEC61000-3-2 (Class A)		
OTHERS	CASE SIZE/WEIGHT	50x127x228.6mm [1.97x5x9 inches] (WxHxD) without terminal block /1.5kg max		
	COOLING METHOD	Convection/Forced air		

\*1 The listed options may affect the published standard specifications. Please contact us for detailed product specification.  
\*2 The current of input surge to a built-in EMI/EMS Filter (0.2ms or less) is excluded.  
\*3 Measured by 20MHz oscilloscope or Ripple-Noise meter (equivalent to KEISOKUGIKEN:RM104). Please refer to the instruction manual 1.8.  
Ripple and ripple noise spec is change at Io=0 to 30% by burst operation.

\*4 Drift is the change in DC output for an eight hours period after a half-hour warm-up at 25°C.  
\*5 When the overcurrent protection continues, the output may be shut down.  
\*6 Applicable when AUX and remote control (optional) is added.  
\*7 Please contact us about another class.  
\* Sound noise may be generated by power supply in case of pulse load.

## Features

- High power & peak power
- High efficiency : 95% typ (Input Voltage 230V, Output Voltage 24V)
- Low profile (50mm, 1.97inch)
- For medical electric equipment (ANSI/AAMI ES60601, EN60601-1 3rd, IEC60601-1-2 4th Ed.)
- Suitable for BF application (Output-FG : 1MOPP, Input-Output : 2MOPP)
- OVC III (according to EN62477-1)
- Complies with SEMI F47 (Refer to Instruction Manual)
- With AUX1 (12V 1A), AUX2 (5V 1A) (Optional)

## Block diagram

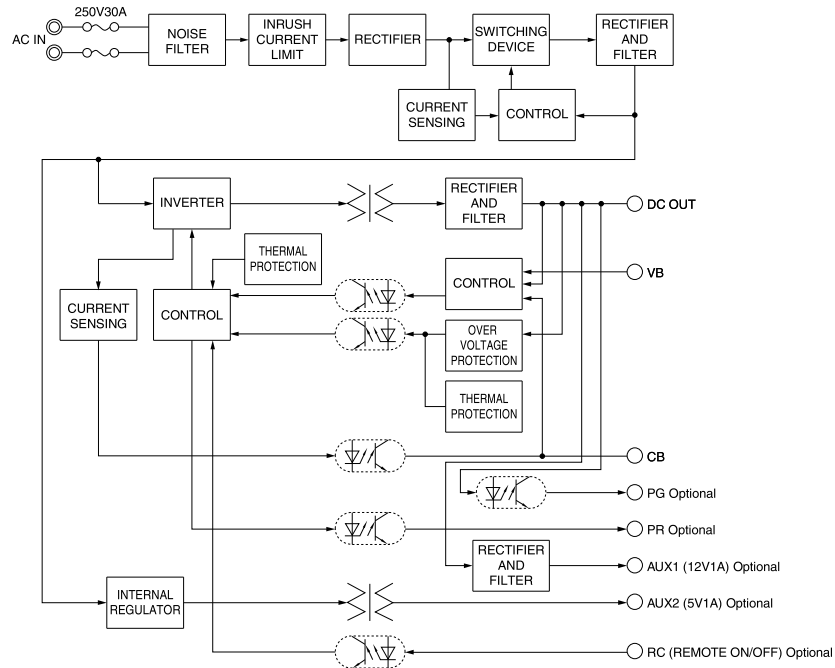

## External view

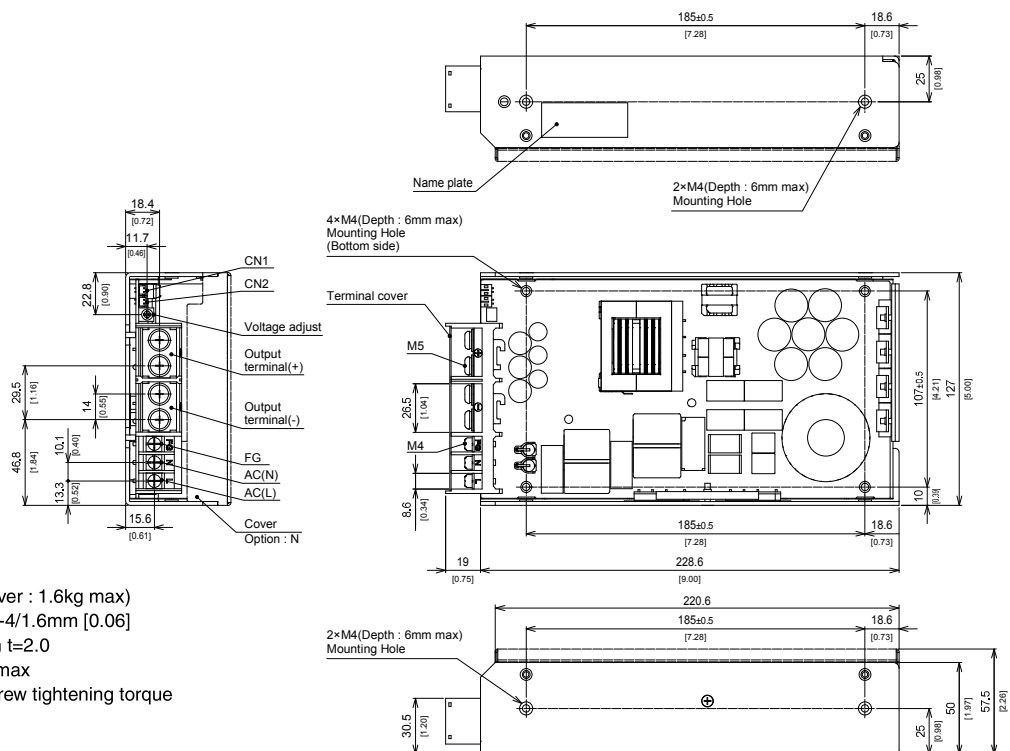

- \* Dimensions in mm [inch]
- \* Tolerance :  $\pm 1$  [ $\pm 0.04$ ]
- \* Weight : 1.5kg max (with Cover : 1.6kg max)
- \* PCB Material/thickness : FR-4/1.6mm [0.06]
- \* Chassis Material : Aluminum  $t=2.0$
- \* Mounting torque :  $1.2N \cdot m$  max
- \* Input and output terminal screw tightening torque  
M4  $1.6N \cdot m$  max  
M5  $2.5N \cdot m$  max
- \* Please connect safety ground to FG terminal on the unit.

**Terminal Blocks**

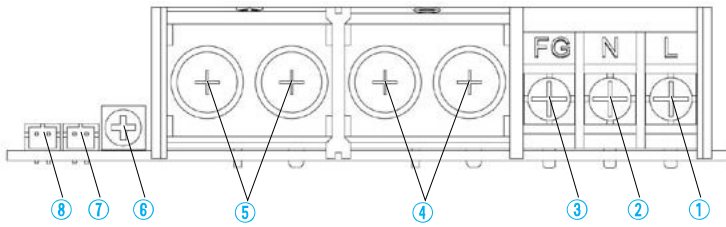

- ① AC (L) (M4)
- ② AC (N) (M4)
- ③ Frame ground (M4)
- ④ - Output (M5)
- ⑤ + Output (M5)
- ⑥ Output voltage adjustable potentiometer
- ⑦ CN2 connector
- ⑧ CN1 connector

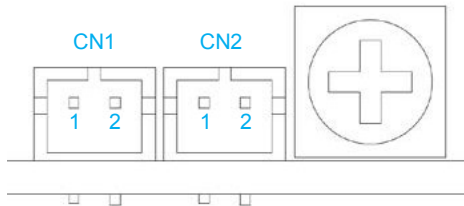

Pin Configuration and Functions of CN1, CN2

Pin No.	Function
1	VB Voltage Balance
2	CB Current Balance

Matching connectors and terminals

Connector	Housing	Terminal	Mfr
CN1	S2B-PH-K-S	Real : SPH-002T-P0.5S Loose : BPH-002T-P0.5S	J.S.T.

**Assembling and Installation Method**

**Installation method**

■The screw should be inserted up to 6mm max from outside of the power supply to keep a distance between inside parts and an isolation.

■When two or more power supplies are used side by side, position them with proper intervals to allow enough air ventilation. Ambient temperature around each power supply should not exceed the temperature range shown in “derating”.

■Fix firmly, considering weight, though it can be used by the installation method shown in right figure.

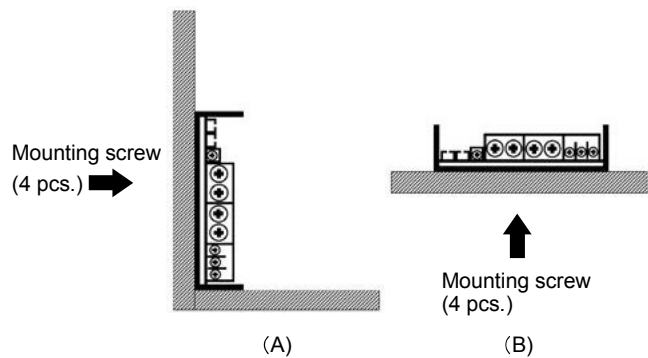
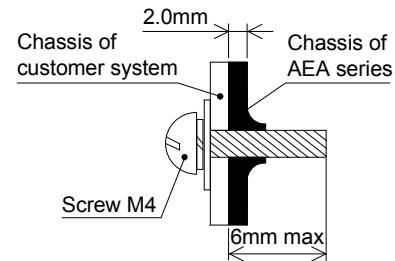

■If mounting on a metal chassis, keep at least 4 mm between the top of the power supply and the chassis for insulation between the components and the chassis.

If the distance between the top of the power supply and the chassis is less than 4mm, insert an insulating sheet with reinforced insulation between the power supply unit and metal chassis.

The following distance is not satisfactory for cooling condition. Please refer to “Derating” for cooling method.

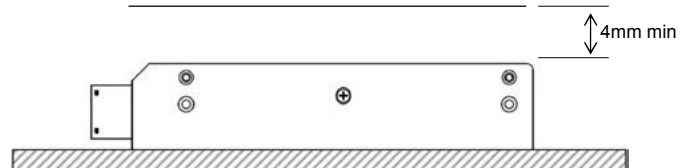

Derating

● AEA600F Derating curve depends on Input voltage

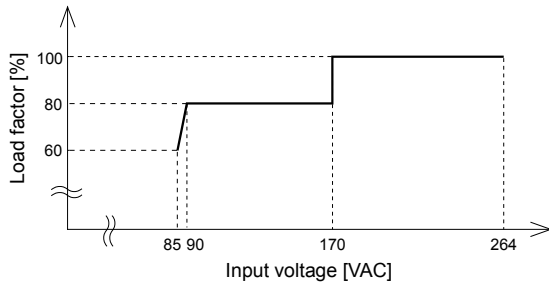

● AEA800F/1000F Derating curve depends on Input voltage

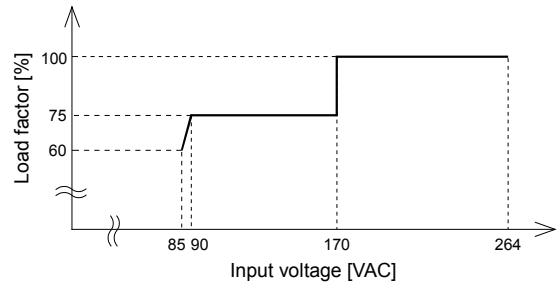

● AEA600F/800F Ambient temperature Derating Curve (convection cooling)

100% Load factor in each derating curve means the rated current (convection cooling) in Specifications.

In the hatched area, the specification of Ripple and Ripple Noise are different from other area.

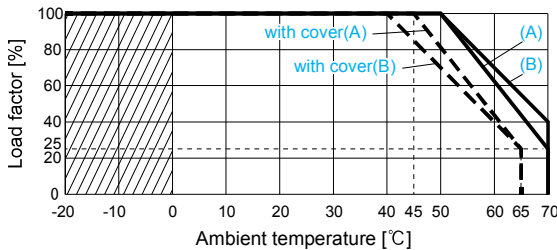

● AEA1000F Ambient temperature Derating Curve (convection cooling)

100% Load factor in each derating curve means the rated current (convection cooling) in Specifications.

In the hatched area, the specification of Ripple and Ripple Noise are different from other area.

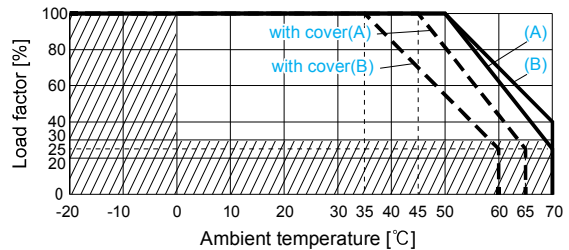

● AEA600F/800F Ambient temperature Derating Curve (forced air cooling)

100% Load factor in each derating curve means the rated current (forced air cooling) in Specifications.

In the hatched area, the specification of Ripple and Ripple Noise are different from other area.

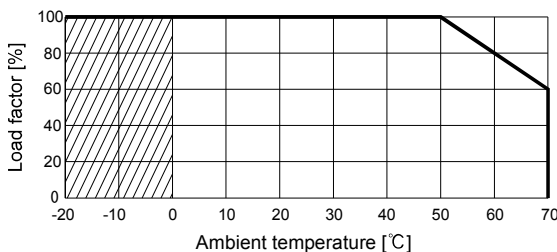

● AEA1000F Ambient temperature Derating Curve (forced air cooling)

100% Load factor in each derating curve means the rated current (forced air cooling) in Specifications.

In the hatched area, the specification of Ripple and Ripple Noise are different from other area.

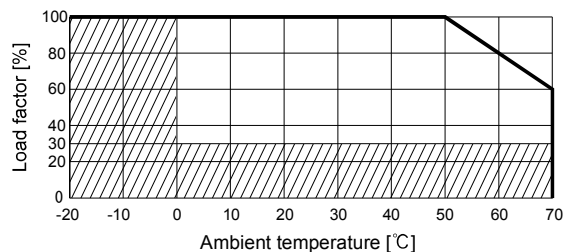

■ Forced air cooling

- AEA600F

① Please satisfy the below temperature at Point A and Point B under the forced air cooling. The Point A/B position is shown in the next figure.

- Point A 90°C or less and Point B 80°C or less at Ta = 50°C
- Point A 110°C or less and Point B 100°C or less at Ta = 70°C

② The forced air should be given to whole of the product.

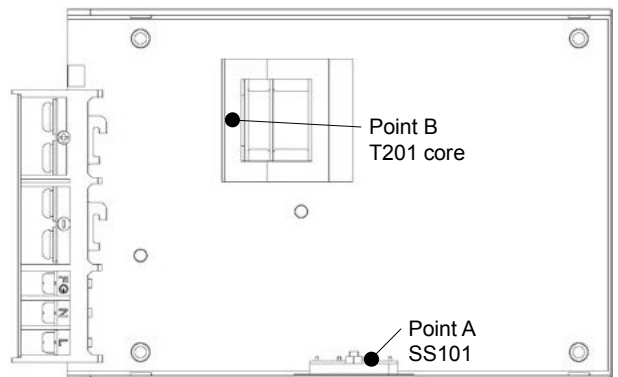
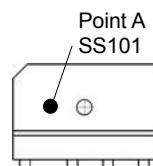

**Derating**

• AEA800F

- ① Please satisfy the below temperature at Point A and Point B under the forced air cooling. The Point A/B position is shown in the next figure.
- Point A 90°C or less and Point B 80°C or less at Ta = 50°C
- Point A 110°C or less and Point B 100°C or less at Ta = 70°C
- ② The forced air should be given to whole of the product.

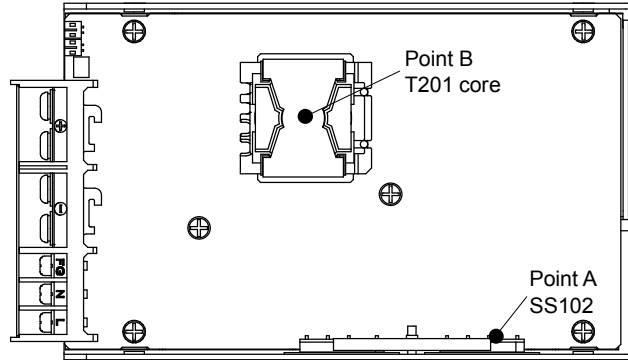
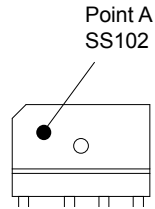

• AEA1000F

- ① Please satisfy the below temperature at Point A and Point B under the forced air cooling. The Point A/B position is shown in the next figure.
- Point A 90°C or less and Point B 80°C or less at Ta = 50°C
- Point A 110°C or less and Point B 100°C or less at Ta = 70°C
- ② The forced air should be given to whole of the product.

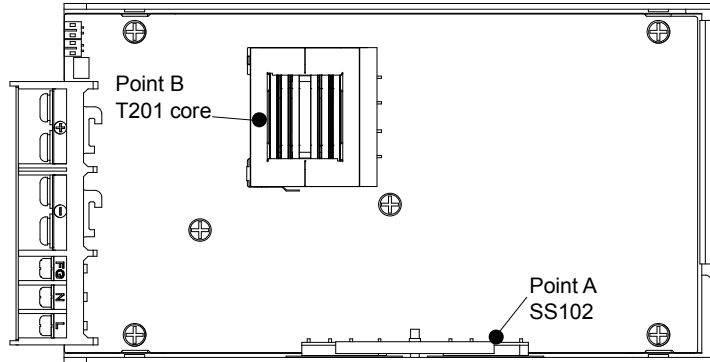
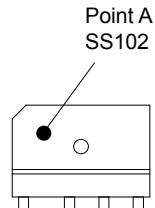

**Instruction Manual**

◆ It is necessary to read the “Instruction Manual” and “Before using our product” before you use our product.

**Basic Characteristics Data**

Model	Circuit method	Switching frequency [kHz]	Input current [A] *1	Inrush current protection	PCB/Pattern			Series/Parallel operation availability	
					Material	Single sided	Double sided	Series operation	Parallel operation
AEA600F	Active filter	65	5.7 (Peak 11.1)	Relay	FR-4	-	Yes	Yes	Yes
	LLC resonant converters	70 - 200							
AEA800F	Active filter	65	6.6 (Peak 14.4)	Relay	FR-4	-	Yes	Yes	Yes
	LLC resonant converters	60 - 200							
AEA1000F	Active filter	65	8.4 (Peak 20.6)	Relay	FR-4	-	Yes	Yes	Yes
	LLC resonant converters	70 - 200							

\*1 The value of input current is at ACIN 100V and rated load (peak).

***Authorised, valued-added distributor***

Australia & New Zealand



**Powerbox Australia Pty Ltd**

Sydney Head Office  
4 Beaumont Road,  
Mt Kuring-Gai, NSW 2080  
Australia

 1800 251 380

 sales@powerbox.com.au

 [powerbox.com.au](http://powerbox.com.au)

**Powerbox Pacific Ltd**

New Zealand Sales Office  
1a Henry Rose Place,  
Albany, Auckland  
New Zealand 0632

 09 4158 320

 sales@powerbox.co.nz

 [powerbox.co.nz](http://powerbox.co.nz)