

PBB13C Series

7-300 WATTS - AC/DC SINGLE OUTPUT

FEATURES

- Universal input 85-264VAC
- Small Size
- Over voltage and current protection
- Power Factor Correction 100-300 Watts
- Chassis mounting
- Decrease power consumption during stand-by 10-15Watts -
- On board in-rush current limiter
- Over current and overvoltage protection
- CE marking
- RoHS compliance

SPECIFICATIONS

INPUT	
Voltage	85-264VAC
Frequency	10-30W (47-440Hz) 50-300W (47-63Hz)
Safety isolation	Input-Output AC 3,000V 1 minute Input - FG AC 2,000V 1 minute Output - FG AC 500V 1 minute
Inrush current	30A typical at 200V AC.
Power factor	0-90 typ., 50-300W
OUTPUT	
Output voltage	See table.
Output current	See table.
Regulation	Line: 20-192mv Model Dependant Load: 40-240mv Model Dependant
Voltage adjustment	Typically $\pm 10\%$
Ripple and noise	See table.
Overvoltage protection	At 115%–140% of rated.
Overcurrent protection	Operates over 105% of rating and recovers automaticall
Temperature drift	20-192mv Model Dependant
Efficiency	See table.
Hold up time	20mS typical (AC in 100V)
Minimum load	Unit will operate with zero load



OPEN FRAME & ENCLOSED

ENVIRONMENTAL	
Operating temperature	-10°C to 70°C.
Derating	Consult Sales Office
Cooling	Convection.
Vibration	10Hz–55Hz, 2G, 3 mins period for 60 minutes along X, Y and Z axis.
Impact	20G, 11mS, once each along X, Y and Z axis.
STANDARDS	
Safety standards	UL60950-1, CSA 60950-1, EN60950-1, EN50178,
C-Tick	AS/NZS CISPR11 Group 1 Class A.
EMI standards	FCC-B, VCCI-B, CISPR-B, EN55011-B, EN5022-B
EMC compliance	EN61204-3, EN61000-6-2 EN61000-4-2 EN61000-4-3 EN61000-4-4 EN61000-4-5 EN61000-4-6 EN61000-4-8 EN61000-4-11
MECHANICAL	
Case size	PBB13C-D-SNY 60 x32 x 93.5mm PBB13C-F-SNY 60 x 32 x 107.5mm PBB13C-H-SNY 60 x 36 x 125mm PBB13C-J-SNY 60 x 36 x 132m PBB13C-L-SNY 60 x 33.5 x 162mm PBB13C-M-SNY 72 x 45 x 185mm PBB13C-R-SNY 85 X 47 X 188mm PBB13C-E-SNY 98 X 59 X 212mm PBB13C-T-SNY 95 X 49 X 222mm
Cable harness	Input/output harness supplied with PSU

PBB13C Series

7-300 WATTS - AC/DC SINGLE OUTPUT

OPEN FRAME & ENCLOSED

SELECTION TABLE

MODEL NUMBER	OUTPUT		RIPPLE & NOISE	EFFICIENCY	POWER
PBB13C-3.3D-SNY	3.3V	2A	120mV p-p	68%	6.6W
PBB13C-5D-SNY	5V	2A	120mV p-p	76%	10W
PBB13C-12D-SNY	12V	0.9A	150mV p-p	79%	10.8W
PBB13C-15D-SNY	15V	0.7A	150mV p-p	80%	10.5W
PBB13C-24D-SNY	24V	0.5A	150mV p-p	83%	12W
PBB13C-3.3F-SNY	3.3V	3A	120mV p-p	69%	9.9W
PBB13C-5F-SNY	5V	3A	120mV p-p	76%	15W
PBB13C-12F-SNY	12V	1.3A	150mV p-p	78%	15.6W
PBB13C-15F-SNY	15V	1A	150mV p-p	80%	15W
PBB13C-24F-SNY	24V	0.7A	150mV p-p	83%	16.8W
PBB13C-3.3H-SNY	3.3V	6A	120mV p-p	75%	19.8W
PBB13C-5H-SNY	5V	6A	120mV p-p	79%	30W
PBB13C-12H-SNY	12V	2.5A	150mV p-p	81%	30W
PBB13C-15H-SNY	15V	2A	150mV p-p	83%	30W
PBB13C-24H-SNY	24V	1.3A	150mV p-p	84%	31.2W
PBB13C-3.3J-SNY	3.3V	10A	120mV p-p	74%	33W
PBB13C-5J-SNY	5V	10A	120mV p-p	79%	50W
PBB13C-12J-SNY	12V	4.3A	150mV p-p	81%	51.6W
PBB13C-15J-SNY	15V	3.5A	150mV p-p	81%	52.2W
PBB13C-24J-SNY	24V	2.1A	150mV p-p	83%	50.4W
PBB13C-36J-SNY	36V	1.4A	250mV p-p	82%	40.4W
PBB13C-48J-SNY	48V	1.1A	250mV p-p	82%	52.8W
PBB13C-3.3L-SNY	3.3V	15A	120mV p-p	75%	49.5W
PBB13C-5L-SNY	5V	15A	120mV p-p	80%	75W
PBB13C-12L-SNY	12V	6.3A	150mV p-p	83%	75.6W
PBB13C-15L-SNY	15V	5A	150mV p-p	83%	75W
PBB13C-24L-SNY	24V	3.2A	150mV p-p	84%	76.8W
PBB13C-36L-SNY	36V	2.1A	250mV p-p	84%	75.6W
PBB13C-48L-SNY	48V	1.6A	250mV p-p	84%	76.8W
PBB13C-3.3M-SNY	3.3V	20A	120mV p-p	78%	66W
PBB13C-5M-SNY	5V	20A	120mV p-p	82%	100W
PBB13C-12M-SNY	12V	8.5A	150mV p-p	82%	102W
PBB13C-15M-SNY	15V	6.7A	150mV p-p	83%	100.5W
PBB13C-24H-SNY	24V	4.3A	150mV p-p	84%	103.2W
PBB13C-24MH-SNY	24V	4.3A (5.0A PK)	300mV p-p	84%	103W (120)
PBB13C-36M-SNY	36V	2.8A	250mV p-p	84%	100.8W
PBB13C-48M-SNY	48V	2.1A	250mV p-p	84%	100.8W
PBB13C-3.3R-SNY	3.3V	30A	120mV p-p	80%	99W
PBB13C-5R-SNY	5V	30A	120mV p-p	84%	150W
PBB13C-12R-SNY	12V	12.5A	150mV p-p	85%	150W
PBB13C-15R-SNY	15V	10A	150mV p-p	85%	150W
PBB13C-24R-SNY	24V	6.3A	150mV p-p	86%	151.2W
PBB13C-24RH-SNY	24V	6.3A (7.5A PK)	300mV p-p	86%	151W (180)
PBB13C-36R-SNY	36V	4.2A	250mV p-p	86%	151.2W
PBB13C-48R-SNY	48V	3.2A	250mV p-p	86%	153.6W
PBB13C-24E-SNY	24V	10A	150mV p-p	84%	151.2W
PBB13C-24EH-SNY	24V	10A (12.5A PK)	300mV p-p	84%	151W (180)
PBB13C-36E-SNY	36V	6.7A	250mV p-p	86%	151.2W
PBB13C-48E-SNY	48V	5A	250mV p-p	86%	153.6W
PBB13C-3.3T-SNY	3.3V	40A	120mV p-p	76%	132W
PBB13C-5T-SNY	5V	40A	120mV p-p	83%	200W
PBB13C-12T-SNY	12V	17A	150mV p-p	83%	204W
PBB13C-15T-SNY	15V	14A	150mV p-p	84%	210W
PBB13C-24T-SNY	24V	12.5A	150mV p-p	87%	300W
PBB13C-24TH-SNY	24V	12.5A (18.8A PK)	300mV p-p	87%	300W (451)
PBB13C-36T-SNY	36V	8.4A	250mV p-p	87%	302.4W
PBB13C-48T-SNY	48V	6.3A	250mV p-p	87%	302.4W

PBB13C Series

7-300 WATTS - AC/DC SINGLE OUTPUT

MECHANICAL DRAWINGS

PBB13C-D

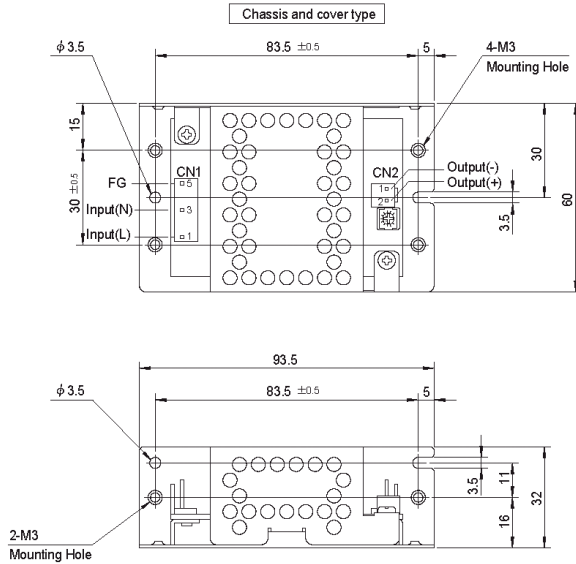

PBB13C-F

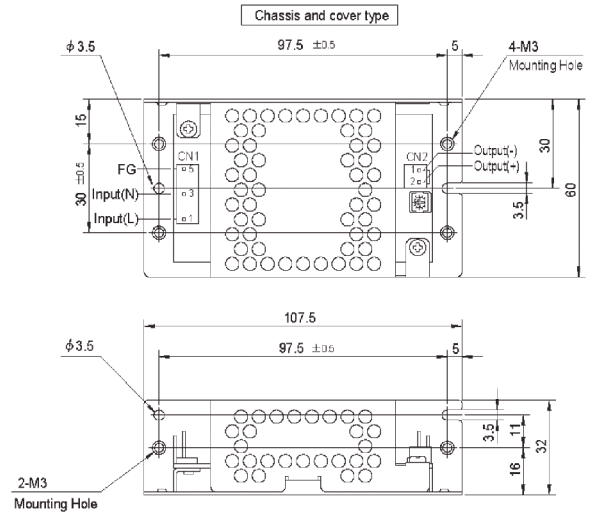

PBB13C-H

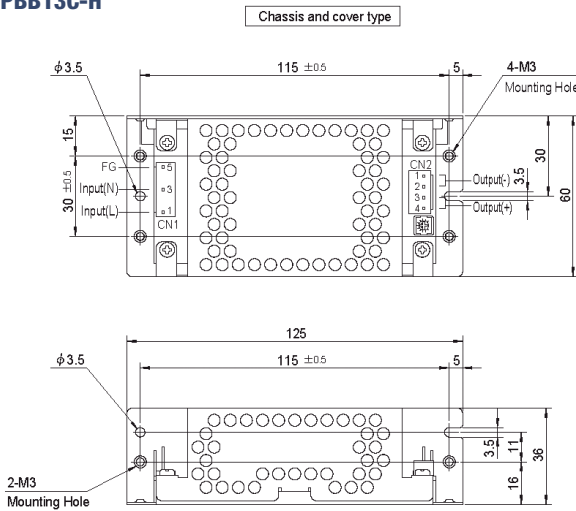

PBB13C-J

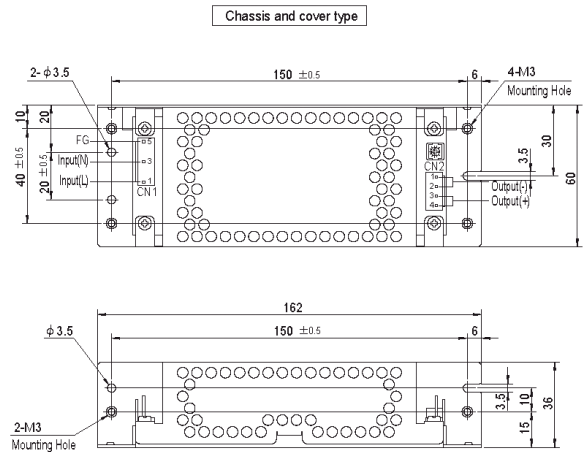

PBB13C-L

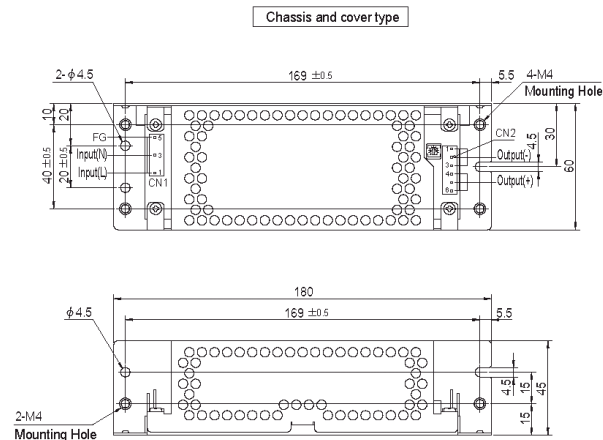

PBB13C-M

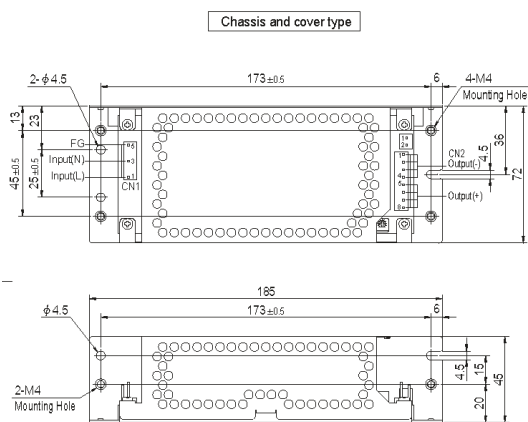

OPEN FRAME & ENCLOSED

PBB13C Series

7-300 WATTS - AC/DC SINGLE OUTPUT

OPEN FRAME & ENCLOSED

MECHANICAL DRAWINGS

PBB13C-R

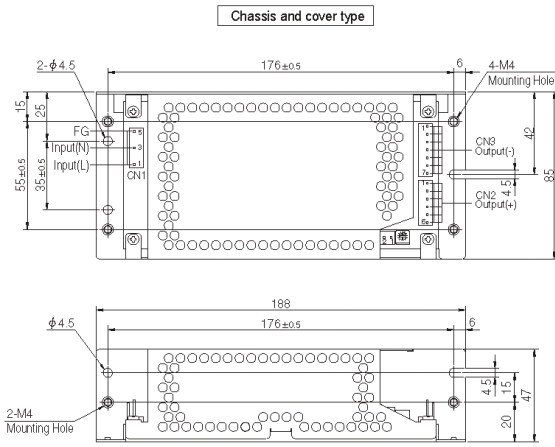

PBB13C-E

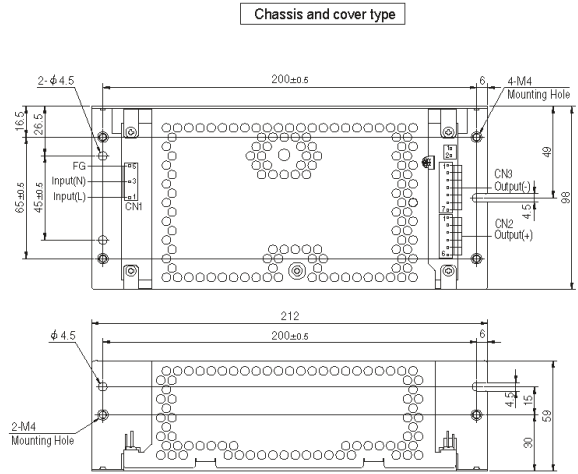

PBB13C-T

